

SENATOR *Small Parts Storage Cabinets*
QUALITY TOOLING



Manufactured from heavy gauge steel, painted finish with transparent polypropylene drawers, allows contents to be viewed when the drawer is closed. The lip on the rear of the drawer allows it to be opened fully without falling out. The cabinets can be stacked or mounted to the wall to maximise use of storage space.

EXTENDED RANGE



Product Number	Cabinet/Drawers	Height (mm)	Width (mm)	Depth (mm)	Weight each	Order Code
SCM008	Cabinet size 8 Drawers @	282 59	306 140	155 140	1.50kg	-5100K
SCS025	Cabinet size 25 Drawers @	238 36.5	306 54	155 140	2.00kg	-5120K
SCM016	Cabinet size 16 Drawers @	551 59	306 140	155 140	2.80kg	-5200K
SCS060	Cabinet size 60 Drawers @	551 36.5	306 54	155 140	4.50kg	-5220K
SCC036	Cabinet size 30 Drawers @ 4 Drawers @ 2 Drawers @	551 36.5 59	306 54 140	155 140 140	4.50kg	-5300K
SCC048	Cabinet size 45 Drawers @ 2 Drawers @ 1 Drawers @	551 36.5 59	306 54 140	155 140 140	4.20kg	-5320K

Drawers to Suit

Drawer Size	Height (mm)	Width (mm)	Depth (mm)	Weight each	Order Code
Small	36.5	54	140		-9600K
Medium	59	140	140		-9620K
Large	59	280	140		-9640K

Dividers to Suit

Drawer Size	Weight each	Order Code
Small 50 x 29mm		-9700K
Medium/Large 50 x 133mm		-9720K

DRAWER CABINETS



KENNEDY Professional Service Case
QUALITY INDUSTRIAL TOOLING

Suitable for transporting and storing smaller items. Manufactured from hi-density industrial strength plastic with opaque lid for viewing contents. Slide clasp-locking mechanism to prevent opening while in transit/storage. Lid and base feature two aligning padlock holes to accept padlocks with shackle diameters up to 5.8mm. The lids have three hinges for strength and durability. Eight fixed compartments supplied with dividers to make up to 16 sections.



Dimensions (W x D x H): 380 x 60 x 335mm.

Size (mm)	Order Code
380 x 60 x 335	KEN-593 -2400K

Service Case Organiser

Robust stacking unit for containing four lockable organiser cases, which lift and slide out. The expandable system allows units to be attached on top or side by side. Cases have translucent lid for selecting contents and multi-positional compartment separators. Used for storing up to 4 service cases.

Dimensions (L x W x H): 425 x 350 x 375mm.

Maximum load: 6kg

It is recommended that no more than three organisers should be stacked at one time.



Size (mm)	Order Code
425 x 350 x 375	KEN-593 -2380K

4 Drawer Parts Cabinet

Manufactured from hi-impact co-polymer polypropylene with opaque drawers for viewing contents. Three section top compartment with opaque lid and moulded snap clasps to prevent accidental opening. Each internal sliding transparent drawer features three removable dividers and locking mechanism to prevent the drawer opening whilst in transit. Recessed top carry handle and locating lugs allows stacking of multiple cabinets.

Dimensions (W x D x H): 390 x 200 x 340mm.



Size (mm)	Order Code
390 x 200 x 340	KEN-593 -1760K

GROUP 593 TOOL POUCHES

KENNEDY
QUALITY INDUSTRIAL TOOLING

Spanner/Toolholder Holster

Manufactured from natural split leather. Two spanner, tan leather. Reinforced joints. Belt not included.



Tools Not Included



Size (mm)	Weight each	Order Code
170 x 110	90g	-3710K

Plier/Wrench Holster

Leather made with a 100 x 45 x 30mm pocket fully stitched and riveted at corners - double riveted at base. Two slots for belt attachment. Belt not included.



Tools Not Included



Size (mm)	Weight each	Order Code
75 x 230	90g	-3740K

Professional Drill Holster

Manufactured from natural split leather, fitted with two additional tool loops and an adjustable drill safety strap, four slits for belt attachment, riveted construction. Tan leather with chuck key holder, adjustable retaining strap and one tool loop. Belt not included.



Tools Not Included



Size (mm)	Weight each	Order Code
300 x 200	250g	-3160K



Plier/Wrench Holster

Manufactured from natural split leather. 90mm tapered pouch with a 40 x 25mm opening. Fully riveted construction. Two slots for belt attachment. Belt not included.



Tools Not Included



Size (mm)	Weight each	Order Code
85 x 90	100g	-3800K

Carpenter's Full Bib Apron

100% cotton drill, with cotton neck loop and ties. Two single stitched pockets.

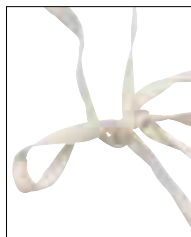

Size (mm)	Weight each	Order Code
850 x 620	200g	-4010K

Hammer Holster

With pivoting metal hammer loop, riveted onto natural split leather, with two slits for belt attachment. Belt not included.



Tools Not Included



Size (mm)	Weight each	Order Code
100 x 150	130g	-3100K

Trimming Knife Holster

Manufactured from natural split leather. 100mm tapered pocket with a 40 x 20mm opening. Fully riveted construction. Two slits for belt attachment. Belt not included.



Tools Not Included



Size (mm)	Weight each	Order Code
60 x 190	80g	-3750K

Mobile Phone Cases - Polyester

Heavy duty polyester with stitched webbing trim. Front flap opening secured with velcro with optional webbing belt loop or stainless steel double capped riveted clip.



Size	Weight each	Order Code
5" x 2 1/2" x 1"	0.45g	-5010K

Hammer & Tool Holster

Manufactured from natural split leather with four medium and one large leather tool loops. Riveted metal tool clip with metal T-bar and chain. Six slits for attaching to belt. Fully riveted construction. Belt not included.



Tools Not Included



Size (mm)	Weight each	Order Code
240 x 75	150g	-3140K

Hand Tools



KENNEDY Nail Bag - Nylon
QUALITY INDUSTRIAL TOOLING

Heavy duty polyester allows exceptional resistance to punctures or tears. Heavily stitched webbing belt complete with heavy duty double capped riveted clasp for added strength and support.

NEW



Size	Weight each	Order Code
20 ³ / ₄ " x 11 ¹ / ₂ " x 1 ¹ / ₄ "	0.31kg	KEN-593 -3540K

Nail Bag - Polyester

Heavy duty polyester allows exceptional resistance to punctures or tears. Heavily stitched webbing on belt loop and edges, and double capped riveted for added strength and support.

NEW



Size	Type	Weight each	Order Code
14 ³ / ₄ " x 11 ¹ / ₄ " x 7 ⁷ / ₈ "	Single	0.2kg	KEN-593 -3530K

Leather Belts - Heavy Duty

Heavy duty natural split leather with heavy buckle and retaining loop.



Size (mm)	Weight each	Order Code
1170 x 50	260g	KEN-593 -3000K
1170 x 40	210g	-3020K

Leather Belt - Heavy Duty

Heavy duty oil tan belt with brass buckle and rivets for use with Kennedy tool pouches.

NEW



Size (mm)	Weight each	Order Code
1170 x 50		KEN-593 -3080K

Polyester & Nylon Belts

Adjustable webbing. Riveted for added strength and support.



Type	Size (mm)	Order Code
Brown	1170 x 50	KEN-593 -3040K
Black	1200 x 50	-3060K

Nail Pouches - Leather

Leather, one pocket and one loop. Stitched bottom seam. Belt not supplied.



Size (mm)	Weight each	Order Code
300 x 250	150g	KEN-593 -3550K

Leather, two pockets, one loop, deep pocket. Double stitched seams with riveted corners for extra strength.



Size (mm)	Weight each	Order Code
360 x 250	370g	KEN-593 -3340K

Nail Pouch - Leather

Leather, two pockets and one loop. Double stitched seams with riveted corners for extra strength. Webbed nylon belt.



Size (mm)	Weight each	Order Code
370 x 220	290g	KEN-593 -3240K

GROUP 593 TOOL POUCHES

KENNEDY *Combination Pouches*
QUALITY INDUSTRIAL TOOLING

Manufactured from leather with a fully riveted double stitched construction. Chrome leather, five pockets and one loop. Belt not included.



Tools Not Included

Size (mm)	Weight each	Order Code
210 x 250	340g	KEN-593 -3450K

Leather made with five pockets and one loop. Belt not included.



Tools Not Included

Size (mm)	Weight each	Order Code
250 x 280	360g	KEN-593 -3460K

Leather made with five pockets, two loops, webbing belt and tape holder.

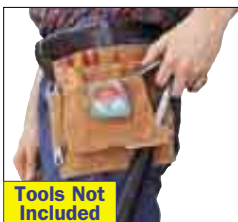

Tools Not Included

Size (mm)	Weight each	Order Code
220 x 210	300g	KEN-593 -3470K

Combination Pouches

Leather made with one pocket, two loops and nail pouch. Belt not included.



Tools Not Included

Size (mm)	Weight each	Order Code
280 x 270	310g	KEN-593 -3600K

Leather made with ten pockets, two loops, webbing belt and tape holder.



Tools Not Included

Size (mm)	Weight each	Order Code
550 x 220	330g	KEN-593 -3500K

Leather made with 8 deep pockets, two nail pouches, two loops, webbing belt and tape holder.



Tools Not Included

Size (mm)	Weight each	Order Code
550 x 220	670g	KEN-593 -3510K

Hand Tools

KENNEDY Tool Pouches
QUALITY INDUSTRIAL TOOLING®

Manufactured from leather. Fully riveted double stitched construction. Chrome leather, two pockets and five loops. Belt not included.



Tools Not Included

Size (mm)	Weight each	Order Code
290 x 200	300g	KEN-593 -3640K

Electrician's Tool Pouch

Manufactured from natural split leather, four pockets, seven tool loops, T-bar and chain, spring clip, tape pocket. Fully riveted construction. Belt not included.



Size (mm)	Weight each	Order Code
200 x 260	410g	KEN-593 -3770K

Double Nail Bag & Combination Tool Pouch

Heavy duty nylon allows exceptional resistance to punctures or tears. Heavily stitched webbing on belt loop and edges, and double capped riveted for added strength and support. 600 denier durable fabric. Double stitched pockets with rivet reinforcement. Six small pockets for pliers, pencils, screwdrivers etc. Two heavy duty steel hammer holders and tape holder. Adjustable belt strap.



Size	Weight each	Order Code
270 x 200 x 50 (x2)		
130 x 120 x 80 (x2)		
140 x 100 x 50 (x1)		-3400K

Double Tool Pouch

10 Pocket 2 Loop Double Tool Pouch - Oil Tan
Manufactured from butt split leather. Fully riveted construction. 10 pockets with t-bar chain and spring clips. Belt supplied separately.



NEW



Size (mm)	Weight each	Order Code
280 x 300		KEN-593 -3260K

Tool Pouch - Large

4 Pocket 2 Loop Tool Pouch - Oil Tan
Large tool pouch with four pockets and two tool loops. Fully brass riveted construction. Manufactured from oil tanned leather.



NEW

Size (mm)	Weight each	Order Code
300 x 230		KEN-593 -3270K

Nail & Tool Pouch - Large

3 Pocket 2 Loop Nail & Tool Pouch - Oil Tan
Large nail and tool pouch with three pockets and two tool loops. Fully brass riveted construction. Manufactured from oil tanned leather.



NEW

Size (mm)	Weight each	Order Code
300 x 230		KEN-593 -3280K

GROUP 593 TOOL ROLLS

KENNEDY PVC Coated Fibre Board Tool Case
QUALITY INDUSTRIAL TOOLING

Waterproof, puncture resistant and rot proof PVC outer encasing rigid fibre board. Grained finish with 36 elasticated tool loops. Full zip around fastener. Black finish.



Tools Not Included

Size (mm)	Weight each	Order Code
315 x 30	350g	KEN-593 -0310K

PVC Multi Tool Rolls

Waterproof, puncture resistant and rot proof PVC outer with heavy duty nylon weave providing a high strength, abrasion resistant inner lining. With flat tool pockets, webbed ties. Tools secured with flap cover.



Tools Not Included

Size (mm)	Weight each	Order Code
390 x 330	190g	KEN-593 -0370K

Tear Resistant Tool Roll

Manufactured from heavy duty tear resistant material with re-enforced stitched edging. Two metal rings for hanging on to a wall when opened. 20 pockets, 18 elasticated tool loops are stitched on the inside. A velcro fastening secures the roll when shut.



Fitted with a riveted carry handle on the outside.



Tools Not Included

Size (mm)	Weight each	Order Code
600 x 540		KEN-593 -0500K

PVC Coated Rayon Tool Rolls

Waterproof, puncture resistant and rot proof PVC outer with soft non-scratch rayon inner to protect tools.

Multi - With 14 pockets. Tools secured by flap cover with two webbed ties.



Tools Not Included

Size (mm)	Weight each	Order Code
650 x 270	270g	KEN-593 -0870K

Multi - With 12 pockets and two pouches. Tools secured by flap cover with two webbed ties.



Tools Not Included

Size (mm)	Weight each	Order Code
750 x 310	420g	KEN-593 -0880K

PVC Double Coated Nylon Multi Tool Roll

Puncture resistant and rot proof PVC outer encasing heavy duty nylon weave. 100% waterproof, easy to clean. With 12 flat, and two pleated pockets, one large end pouch divided into two with a press stud containing flap.

Tools secured with flap cover. Leather tie with metal buckle.



Size (mm)	Weight each	Order Code
700 x 315	340g	KEN-593 -0520K



Tools Not Included

Multi Tool Roll

With 13 flat pockets, single leather wrap around tie with metal buckle fastening. Tools secured with flap cover.



Size (mm)	Weight each	Order Code
430 x 270	190g	KEN-593 -0430K

Tools Not Included

Chisel Tool Roll

Manufactured from PVC coated cotton with eight flat pockets, single leather wrap around tie with metal buckle fastening. Tools secured with flap cover.



Size (mm)	Weight each	Order Code
500 x 370	250g	KEN-593 -0480K

Tools Not Included

PVC Coated Cotton Multi Tool Rolls

Waterproof, puncture resistant and rot-proof PVC outer with medium duty, non-scratch cotton inner. With 15 pleated pockets, two webbed ties. Tools secured with flap cover.



Tools Not Included

Size (mm)	Weight each	Order Code
660 x 320	390g	KEN-593 -0440K

Bench Stone Holder

To suit stone size 200 x 50 x 25mm.



Stone not included

Weight each	Order Code
120g	KEN-593 -7020K

Hand Tools

SENATOR *Canvas Holdall*
QUALITY TOOLING

Manufactured from heavy duty water resistant canvas. Handles wrap underneath the bag for added strength, fitted with a heavy duty zip.



Overall Length	Weight each	Order Code
460 (18")	250g	-0560K
610 (24")	335g	-0580K
760 (30")	360g	-0600K

KENNEDY *Medium Weight Holdalls*
QUALITY INDUSTRIAL TOOLING

Reinforced board base with four riveted plastic feet. Plastic zip fastening, webbing covered rope handles.



Overall Length	Weight each	Order Code
455mm	390g	-0110K
610mm	500g	-0120K

Jumbo Tool Bag

Heavy duty double thickness canvas. Five internal pockets and a fibre board base with six riveted metal feet. Webbing handles and straps with plastic buckles.



Overall Length	Weight each	Order Code
610mm	1.50kg	-0060K



KENNEDY *PVC Tool Bag*
QUALITY INDUSTRIAL TOOLING

PVC holdall riveted leather handle and straps with metal buckles, fibre board base and top. The PVC makes the tool bag puncture-resistant, waterproof and rot-resistant.



Size (mm)	Weight each	Order Code
310	230g	-0100K

Heavy Duty PVC Nylon Coated Canvas Holdalls

Reinforced fibre board base with four riveted metal feet and zip fastening. Webbing covered rope handles and welded D rings at either end.



Overall Length	Weight each	Order Code
455mm	670g	-0180K
610mm	810g	-0240K
760mm	590g	-0300K

Canvas Holdall

Heavy duty water resistant. Canvas covered rope handles, fully stitched, wrap underneath bag for extra support. Three webbed straps with metal buckles for closing, two of which fully wrap around the bag to give extra support.



Overall Length	Weight each	Order Code
760	810g	-0080K

Barn Type Holdalls

Manufactured from butt split leather with wrap around leather handles. Leather fastening straps with metal buckles. Fully riveted construction. Reinforced on corners. Black finish.

Holdall with Shoulder Strap

Manufactured from Butt split leather with wrap around leather handles. Three leather fastening straps with metal buckles and an adjustable shoulder strap. Fully riveted construction. Black finish.



Overall Length	Weight each	Order Code
405mm	1.40kg	-0620K
535mm	1.80kg	-0630K

Overall Length	Weight each	Order Code
500	2.30kg	-0640K

PRODUCTS ARE ONLY AVAILABLE VIA YOUR DISTRIBUTOR

GROUP 593 TOOL BAGS

KENNEDY Electrician's Tool Bag
QUALITY INDUSTRIAL TOOLING



Manufactured from heavy duty tear-resistant material with reinforced stitched edging. Velcro fastening flap with soft touch carry handle and double webbed shoulder strap fixed with metal release clasps. Supplied with two small organiser cases which are stored in two outer pockets. Two removable tool boards (one velcro fastened) are kept inside which have a unique tool storage securing system built in.



KENNEDY Heavy Duty PROFESSIONAL Tool Bag



600 denier durable fabric. Adjustable shoulder strap. 11 internal pockets. 17 external pockets. Large internal compartment. Padded handles and strap. Heavy duty zip.

NEW



Size (mm)	Weight each	Order Code
460		KEN-593 -0940K

Heavy Duty Tool Bag

600 denier durable fabric. Adjustable shoulder strap. 13 external pockets. One large internal compartment. Main compartment can be divided into five pockets using removable divider. Heavy duty water-resistant base for extra strength. Padded handles and strap. Business-card holder and key strap. Heavy duty zip.

NEW



Tools Not Included

Size (mm)	Weight each	Order Code
330		KEN-593 -0980K



Size (L x D x H mm)	Weight each	Order Code
320 x 340 x 125		KEN-593 -0560K

KENNEDY Traditional Style Carpenter's Bag
QUALITY INDUSTRIAL TOOLING

Heavy duty hard wearing canvas, double stitched edging with eight brass eyelets for rope to pass through for closing. Canvas covered rope handles wrap underneath bag, fully stitched and riveted at opening for extra support. One internal pocket (200 x 130mm).



Size (mm)	Weight each	Order Code
840	680g	KEN-593 -0030K
1065	790g	-0040K

Hand Tools

KENNEDY Professional Service Case
QUALITY INDUSTRIAL TOOLING

Hard wearing cordura with nylon reinforced webbing handles. Two tool boards and unique repositionable tool retaining system, ceramic sheath for hot soldering irons and three press stud pockets. Zippable.



KENNEDY Lightweight Bag & Case
QUALITY INDUSTRIAL TOOLING



Manufactured in heavy duty wear-resistant nylon which is water-resistant and ideal for use in low temperatures fitted with two outer pockets with velcro fastening. The corners have rubber protection for extra durability, fitted with four rubber feet, outer carry handles, telescopic handle and wheels with a padlockable zip fastening. Inside there is a removable toolboard with one velcro fastening pocket and 11 tool pockets, one hinged toolboard with 12 elasticated tool loops and 13 tool pockets and a plastic storage compartment with adjustable dividers.



Tools Not Included

Size (mm)	Weight each	Order Code
450 x 330 x 80	2.10kg	KEN-593 -2850K

KENNEDY Heavy Duty Professional Tool Caddy
QUALITY INDUSTRIAL TOOLING



600 denier durable fabric. Adjustable shoulder strap. Locking telescopic handle. 26 internal pockets. 12 external pockets. Large internal compartment. Padded handles and strap. Heavy duty zip.

NEW



Size (mm)	Weight each	Order Code
460		KEN-593 -0960K



Tools Not Included

Size (mm)	Weight each	Order Code
460 x 360 x 145		KEN-593 -2760K

Hand Tools

GROUP 593 TOOL CASES

SENATOR Service Engineer's Aluminium Tool Case

Heavy duty case for tool storage, ideal for the mobile service-engineer. Prices the storage of many tools with the professional look of a briefcase. Silver aluminium with reinforced edges and corners. Internal base compartment is fitted with adjustable dividers to offer choice of sizes. Removable rigid tool board stored in the lid with 17 pockets of various sizes. Supplied with fixed handle and two security locks and keys.



Size (mm)	Weight each	Order Code
457 x 330 x 150	3.00kg	SEN-593 -4400K

Executive Engineer's Aluminium Tool Case

Large, lightweight case for tool storage, ideal for the mobile engineer. Prices the storage and portability of a large amount of tooling with the professional look of a briefcase. Black aluminium case with silver reinforced edges and corners. Internal base compartment is fitted with adjustable dividers to offer choice of sizes. Removable rigid tool board stored in the lid with 17 pockets of various sizes. 1" wide, length adjustable lightweight nylon shoulder strap with rubber shoulder protector for added comfort. Supplied with fixed handle and two security locks and keys.



Size (mm)	Weight each	Order Code
457 x 330 x 150	5.70kg	SEN-593 -4360K

Cantilever Aluminium Tool Case

Heavy duty case for tool storage, ideal for the mobile technician. Prices the storage and portability of many tools with the professional look of a briefcase. Silver aluminium with reinforced edges and corners. Concealed cantilever mechanism. Large base compartment with four cantilever trays to make all contents instantly available. Compartment dividers are adjustable to offer choice of sizes. 1" wide, length adjustable lightweight nylon shoulder strap, with rubber shoulder protector for added comfort. Supplied with fixed handle and two security locks and keys.



Size (mm)	Weight each	Order Code
360 x 220 x 245	3.10kg	SEN-593 -4600K

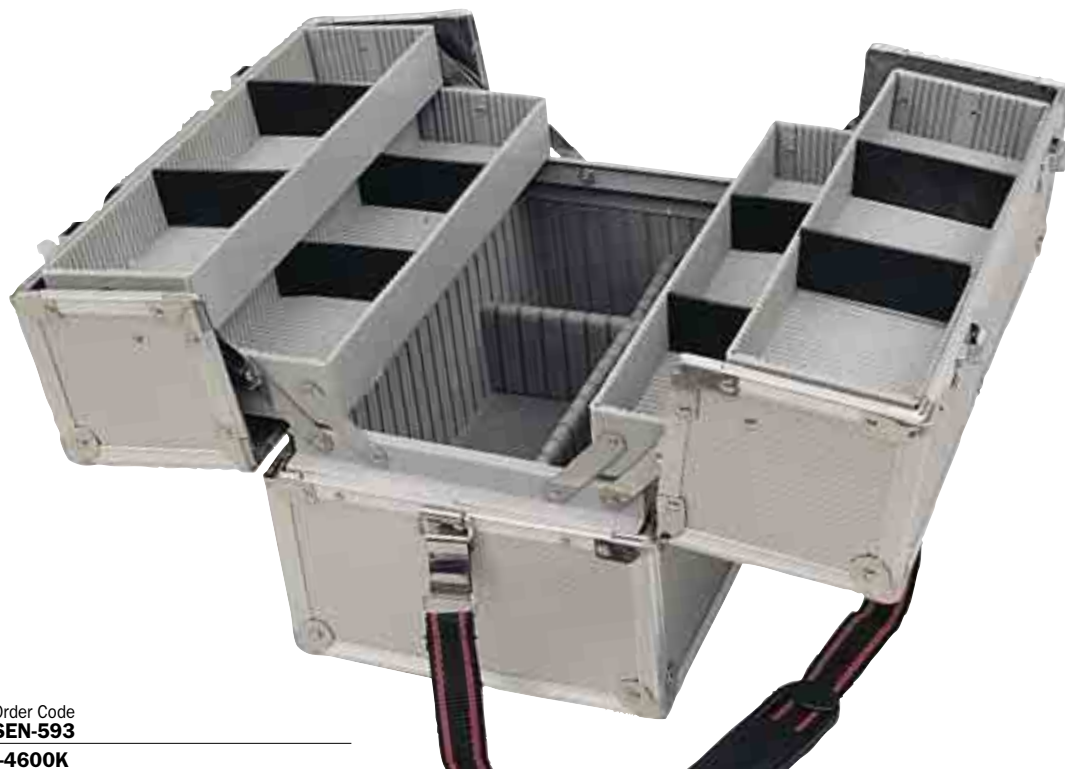

Hand Tools



KENNEDY Aluminium Reinforced Case
QUALITY INDUSTRIAL TOOLING

Impact resistant case. Two removable tool boards with elasticated tool retaining loops, one with document pocket, divided storage compartment. Double locking with two keys.



Heavy Duty Aluminium Case

High strength, impact resistant case. Reinforced edges and hinges. Rubber padded handle for comfort. Two fitted and hinged tool boards with elasticated tool retaining loops, two expandable document pockets and divided storage compartment. Double locking with two keys.



Tools Not Included

Tools Not Included

Size (mm)	Weight each	Order Code
445 x 340 x 190	2.85kg	KEN-593 -2550K

Size (mm)	Weight each	Order Code
480 x 360 x 185	2.60kg	KEN-593 -2650K

Impact Resistant Service Case

Ribbed high strength plastic case with aluminium reinforced trim. Two fitted and hinged tool boards with elasticated tool retaining loops. Lockable with two keys. Padded carry handle.



Impact Resistant Plastic Case

High strength ribbed double wall constructed case. Two fitted hinged tool boards with elasticated tool retaining loops, four repositionable dividers in the bottom compartment, expandable document pocket in the lid and two removable small parts trays. Double locking with two keys.



Tools Not Included

Tools Not Included

Size (mm)	Weight each	Order Code
430 x 340 x 160	2.95kg	KEN-593 -2450K

Size (mm)	Weight each	Order Code
465 x 350 x 200	2.85kg	KEN-593 -2500K

PRODUCTS ARE ONLY AVAILABLE VIA YOUR DISTRIBUTOR

GROUP 593 TOOL CASES

KENNEDY Heavy Duty Aluminium Tool Case
QUALITY INDUSTRIAL TOOLING

Manufactured from composite aluminium and rubber resin which is normally used in the automotive industry. Chromed steel hinges with lid support mechanism, two chromed steel locks with keys, a heavy duty plastic handle and four rubber feet. Inside are two secured hinged tool boards, each with 31 elasticated tool loops, an expandable document compartment, two small organisers and a customisable storage compartment with repositional dividers.



Tools Not Included

Size (mm)	Weight each	Order Code
466 x 340 x 190		KEN-593 -2740K

High Impact Resistant Tool Case

Manufactured from composite aluminium and rubber resin which is normally used in the automotive industry. Chromed steel hinges with lid support mechanism, two chromed steel locks with keys, a heavy duty plastic handle and four rubber feet. Inside are two secured hinged tool boards, each with 31 elasticated tool loops, an expandable document compartment, two small organisers and a customisable storage compartment with repositional dividers.



Tools Not Included

Size (mm)	Weight each	Order Code
470 x 390 x 347		KEN-593 -2780K

Service Engineer's Case

Service case with wheels. Case manufactured from high impact double walled polyethylene shell, corrosion-resistant and aluminium reinforced. Full length heavy duty piano hinges and trim. Two expandable document pockets, two hinged and fitted tool boards with elasticated tool retaining loops.

Shockproof vacuum formed polystyrene bottom storage tray with fixed compartments supplied complete with four small component boxes.

The two 38mm wide rubber wheels and retractable telescopic aluminium handle allows the case to be moved when fully loaded with the minimum of effort. Double locking with two keys.

Strong enough to be used to transport tools when travelling by aircraft.



Tools Not Included

Size (mm)	Weight each	Order Code
485 x 370 x 190	5.70kg	KEN-593 -2700K

Hand Tools



KENNEDY *Tool Box with Tote Tray & Organiser*
QUALITY INDUSTRIAL TOOLING

Manufactured from impact resistant high-density plastic. Internal eight compartment tote tray with retractable carry handle and stacking 16-compartment organiser. Features transparent organiser lid with internal locking clasps, moulded metric rule on the lid, lid locking clasps and sturdy plastic handle that also locks lid shut when lifting. Padlock hole and piano hinges. Dimensions (W x D x H): 480 x 240 x 260mm.



Description	Size (mm)	Order Code
Tool Box with Tote Tray & Organiser	480 x 240 x 260	KEN-593 -2320K

4 Drawer Tool Chest

Manufactured from hi-impact co-polymer polypropylene. Features four sliding drawers enclosed with a slide clasp front panel to prevent opening whilst in transit. Top carry handle with soft touch grip zone and large locking clasps. Metric graduated V-groove in the lid securely holds work piece while being cut. Front cover panel and lid have aligning padlock hole for optional added security. Dimensions (W x D x H): 450 x 250 x 325mm.



Tools Not Included

Description	Size (mm)	Order Code
4 Drawer Tool Chest	450 x 250 x 325	KEN-593 -1500K

Tool Container with Drawer

Manufactured from impact-resistant polypropylene co-polymer. Internal sliding transparent drawer features removable dividers and locking mechanism to prevent the drawer opening whilst in transit. Internal removable tool pots and pivoting carry handle. Dimensions (W x D x H): 465 x 330 x 640mm.



Description	Size (mm)	Order Code
Tool Container with Drawer	450 x 320 x 215	KEN-593 -1080K

Tool Box with Tote Tray

Manufactured from impact resistant high-density plastic. Internal eight compartment tote tray. Features moulded metric rule on the lid, lid locking clasps and sturdy plastic handle that also locks lid shut when lifting. Padlock hole and piano hinges. Dimensions (W x D x H): 445 x 240 x 220mm.



Description	Size (mm)	Order Code
Tool Box with Tote Tray	445 x 240 x 220	KEN-593 -2300K

Power Tool Case

Sturdy plastic case, suitable for a variety of tools, such as angle grinders, honing machines, drills, planes, sanders, etc.



Description	Size (mm)	Order Code
Power Tool Case	420 x 260 x 160	KEN-593 -1020K

Industrial Power Tool Tidy

Metal case manufactured from thick gauge steel with double folded seams. Designed for storing and transporting portable power tools and other items that require an industrial case for protection.



Width (mm)	Depth (mm)	Height (mm)	Weight each	Order Code
270	115	400	1.40kg	KEN-593 -1000K

Hand Tools

GROUP 593 TOOL BOXES

KENNEDY Mobile Tool Cabinet
QUALITY INDUSTRIAL TOOLING

Manufactured from hi-impact co-polymer polypropylene. Large tilt opening parts bin. Sliding drawers with locking mechanism to prevent the drawer opening whilst in transit. Top carry handle with soft touch grip zone and large locking clasps. Internal four compartment tote tray. Top box and parts bin both feature aligning holes to suit padlocks with shackle diameters of up to 7.4mm. Metric graduated V-groove in the lid securely holds work piece while being cut. Trolley handle is height adjustable. Rear 'H' hooks for storing extension leads and large wheels for easy movement. Dimensions (W x D x H): 490 x 330 x 720mm.



Description	Size (mm)	Order Code
Mobile Tool Cabinet	490 x 380 x 720	-1800K

Tool Box with Tote & Wheels



Manufactured from impact resistant high-density plastic. Recessed rigid handle for tilting box onto wheels for easy transportation. Large clasps to lock lid when in transit/ storage and padlock hole for added security. Recessed carrying handle allows stacking. Lid features three opaque internal removable trays with removable dividers for small parts storage. Five-compartment tote tray also features opaque lids on the two end compartments with moulded snap clasps to prevent accidental opening. Dimensions (W x D x H): 645 x 280 x 300mm.



Size (mm)	Weight Capacity	Order Code
645 x 280 x 300	3 - 30kg	KEN-593 -2340K

Mobile Tool Box

Sturdy mobile tool box with a large lower storage area for power tools, etc. The tool box has two nested tote trays for smaller tools. The lockable lid has two storage compartments for fixings. The integral handle slides out for ease of transport.



Description	Size (mm)	Order Code
Mobile Tool Box	550 x 350 x 475	KEN-593 -2000K

Multi Utility Storage Box



A lightweight high capacity injection moulded polypropylene box for tough, heavy duty use. Ideal for indoor or outdoor use where high loading capacity is needed such as on construction sites, premises maintenance, transport, nautical equipment. Water resistant design and integral lifting grips on both sides. The lid features a full length steel pin hinge with 'positive pressure' cam style clasping mechanism that seals the case to create a water resistant closure. Also features integral trolley suitcase style wheels and a pull-out handle, a robust fold flat carry handle and a slide out clear ID/nameplate holder. Shock resistant and corrosion proof. Can be used in high or low temperature environments. With moulded padlocking hasp and stacking locators.



Description	Size (mm)	Order Code
Storage Box	780 x 410 x 330mm	KEN-593 -1600K

Hand Tools

KENNEDY 17" Industrial Cantilever Tool Box
QUALITY INDUSTRIAL TOOLING



Manufactured from industrial quality steel with all welded construction. Durable corrosion-resistant two part epoxy powder coat finish. Two piece cantilever lids with padlock hole for additional security. Large base compartment with four partitioned, instant access cantilever trays for additional storage. Full width carry handle also automatically closes trays when lifting.

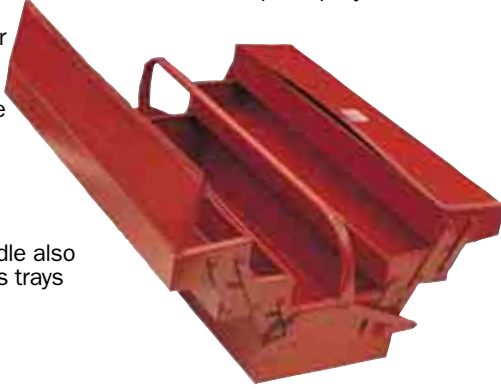

Overall Length	Overall Width	Overall Depth	Weight each	Order Code
430mm	205mm	205mm	5.30kg	-1170K
560mm	205mm	205mm	6.10kg	-1210K

Barn Type Tool Boxes

Manufactured from heavy gauge steel of rigid construction for continuous industrial use. Large base compartment for larger items and removable tote tray for smaller and most used items. Hard wearing cellulose paint finish. Two piece lid doors that overlap with padlock hole for added security. Full width piano hinges provide rigidity and strength. Supplied with fixed carry handle on the lid.



Overall Length	Overall Width	Overall Depth	Weight each	Order Code
355mm	205mm	185mm	3.00kg	-2140K
480mm	205mm	185mm	4.40kg	-2190K
610mm	205mm	185mm	5.10kg	-2240K

SENATOR Tool Boxes
QUALITY TOOLING



17" & 21" Cantilever Tool Boxes

Steel construction with two piece cantilever lids with padlock hole for additional security. Large base compartment with four easy access cantilever trays for additional storage. The full width carry handle automatically closes the trays when lifting.

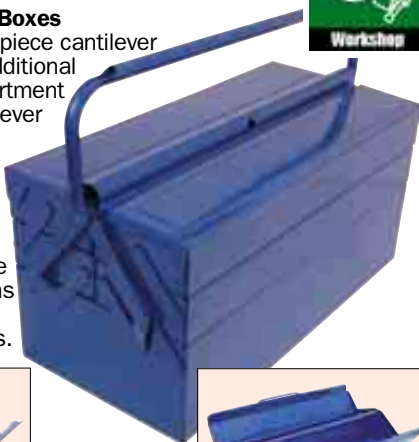

14" Barn Type Tool Box

Steel construction with base compartment for larger items and removable upper tray for smaller most used items.



-1370K



-1540K

Size (L x W x D) (mm)	Order Code
14" Barn Type	-1540K
17" 4 Tray	-1370K
21" 4 Tray	-1410K

KENNEDY Heavy Duty PROFESSIONAL Tool Boxes



Manufactured from heavy gauge steel, all welded construction. Durable and corrosion resistant two part epoxy powder paint finish. With quick release lid clasps, padlock hasps and textured carry handles. Full width piano hinges provide rigidity and strength, ensuring smooth operation and additional security.

Top Opening Type

Manufactured from heavy gauge steel with all welded construction. Durable corrosion resistant two part epoxy powder coat finish. Quick release lid clasps and removable tote tray for smaller tools and components. Can be padlocked for additional security (padlock not included). Supplied with fixed carry handle on the lid.



Width (mm)	Depth (mm)	Height (mm)	Weight each	Order Code
483	180	180	3.65kg	-0040K
508	218	243	6.35kg	-0060K

18" Professional Cantilever

Manufactured from heavy gauge steel with all welded construction for continuous industrial use. Durable corrosion resistant two part epoxy powder coat finish. Fully enclosed cantilever mechanism for added security. Quick release lid clasps with padlock hole for security. Two piece cantilever lids that can be padlocked for additional security (padlock not included). Full width piano hinges provide rigidity and strength. Large base compartment (450 x 260 x 170mm) with four cantilever trays for additional storage. The cantilever action of the top trays makes tray contents instantly available. Supplied with fixed carry handle on the lid.



Width (mm)	Depth (mm)	Height (mm)	Weight each	Order Code
459	255	333	9.10kg	-0140K

Hand Tools

GROUP 594 ROLLER CABINETS & TOOL CHESTS

KENNEDY Portable Professional Tool Chest



Manufactured from heavy gauge steel with all welded construction. Durable and corrosion resistant two part epoxy powder paint finish. With quick release lid clasps, padlock hasps and textured carry handles. Full width piano hinges provide rigidity and strength, ensuring smooth operation and additional security. Three full-length drawers with rigid aluminium edged handles. Fully Lockable unit with a handle on the top and a carry handle on each end. The lid automatically locks all of the closed drawers when lowered to prevent opening.

Height: 340mm, Depth: 215mm, Width: 520mm

Drawer sizes: 2@ 460 x 180 x 55mm. 1@ 460 x 180 x 75mm.



Width (mm)	Depth (mm)	Height (mm)	Weight each	Order Code
520	215	340	10.4kg	KEN-594 -0120K

Heavy Duty Tool Boxes

Manufactured from heavy gauge steel, all welded construction. Durable and corrosion resistant two part epoxy powder paint finish. With quick release lid clasps, padlock hasps and textured carry handles. Full width piano hinges provide rigidity and strength, ensuring smooth operation and additional security.

Portable Tool Chest

Two full-length drawers with rigid aluminium lipped handles. Automatically locks the drawers when the lid is closed, to prevent accidental opening.

Drawer size:
508 x 190 x 76mm.



Width (mm)	Depth (mm)	Height (mm)	Weight each	Order Code
534	218	288	10.4kg	KEN-594 -0100K

YAMOTO 4 Drawer Service Cart



Industrial all steel construction with a Hi-Vis yellow and grey spray paint finish. Full width piano hinge. Chrome oval handle for comfort. Double extending ball bearing drawer runners for full drawer depth opening and smooth operation. 4x 4" solid rubber castors with 360 degree rotation. Two rear castors feature lever locking mechanism to reduce unwanted movement. Large open base bay. Lid stays to hold the lid in a vertical position when in use. Protective drawer liners prevent scratching and reduce tool noise. Double locking system: Drawer lever locking mechanism within top tool bay. Key locking drop down lid for the top tool bay. Supplied flat packed for on-site assembly.

Overall dimensions (W x H x D): 770 x 960 x 520mm.

2 drawers (W x H x D Internal): 300 x 70 x 440mm.

2 drawers (W x H x D Internal): 640 x 70 x 440mm.

Maximum capacities:

Drawers:

40kg/drawer. Overall: 280kg.

Top tool bay:

675mm x 450mm

storage.

2x 35mm x 470mm

tool storage.

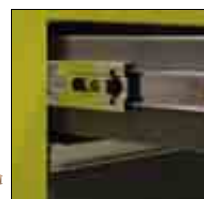

Ball Bearing Drawer Runners



Internal Tool Rack

Width (mm)	Depth (mm)	Height (mm)	Weight each	Order Code
855	500	960	53.0kg	YMT-594 -2040K

Description	Order Code
Replacement 90° Lock Set	-6800K
Ball Bearing Drawer Sliders (Pair)	-7100K

SENATOR 3 Tray Quality Tooling Trolley



Bolted steel construction. 100mm industrial castors. Brakes fitted to two end castors. Hard wearing powder coated finish.



Overall Length	Overall Width	Overall Depth	Weight each	Order Code
737mm	383mm	663mm	3.70kg	SEN-594 -4030K

Hand Tools

SENATOR *Roller Cabinet*
QUALITY TOOLING

Double thickness side walls with welded joints and a hard wearing epoxy powder coating. I-Beam draw slides with double sliders on base drawer. 100mm rubber castors with brakes fitted to two end castors. Fully locking. Castors are rated to 40kg capacity standing load per castor. Drawer loads should be evenly distributed. Roller cabinets are not suitable for frequent relocation when loaded and when moved should only ever be pushed.

7 Drawer

Drawer sizes:

- 4 @ 590 x 410 x 50mm.
- 2 @ 590 x 410 x 100mm.
- 1 @ 590 x 410 x 200mm.

Uses 16" drawer slides.

For Spares see Page 536



Spares	Order Code
Lock	SPR-567-7210K
Key Blank	SPR-567-7320K
Draw Slide	SPR-567-7050K
Castors	SPR-567-6900K
Top Mat	SPR-567-7560K
Draw Liner	SPR-567-6610K

For Prices see Page 536



Colour	Width (mm)	Depth (mm)	Height (mm)	Weight each	Order Code
Red	670	460	885	51kg	-0580K

Tool Chests

For the cost conscious, DIY and light industrial use.



3 Drawer

Piano hinged lid. Carry handle. Cantilever top tray. Fully locking.

Drawer sizes:

- 3 @ 450 x 190 x 55mm.

Uses 10" drawer slides.

Type A lid stays.



Spares	Order Code
Lock	SPR-567-7200K
Key Blank	SPR-567-7300K
Draw Slide	SPR-567-7020K
Draw Liner	SPR-567-6610K

For Prices see Page 536

Colour	Width (mm)	Depth (mm)	Height (mm)	Weight each	Order Code
Red	520	218	304	20kg	-0200K

6 Drawer

Piano hinge. Carry handles. Tote tray. Fully locking. Two wall construction side panels. Beam draw slides.

Drawer sizes:

- 2 @ 50 x 125 x 280mm.
- 1 @ 50 x 280 x 280mm.
- 2 @ 50 x 590 x 280mm.
- 1 @ 100 x 590 x 280mm.

Uses 10" drawer slides.

Type A lid stays.



Spares	Order Code
Lock	SPR567-7240K
Key Blank	SPR567-7320K
Draw Slide	SPR567-7020K
Lid Stay	SPR567-6950K
Draw Liner	SPR567-6610K

For Prices see Page 536

Colour	Width (mm)	Depth (mm)	Height (mm)	Weight each	Order Code
Red	670	320	390	26kg	-0240K

Roller Cabinet

Hard wearing epoxy coated steel fabricated construction. Fully locking. I-Beam draw slides with double sliders on base drawer. 100mm rubber castors with brakes fitted to two end castors. Castors are rated to 40kg capacity standing load per castor. Drawer loads should be evenly distributed. Roller cabinets are not suitable for frequent relocation when loaded.

3 Drawer

Drawer sizes (W x D x H):

- 3 @ 511 x 403 x 75mm.

Bottom Compartment (W x D x H):

- 678 x 425 x 368mm.



Spares	Order Code
Lock	SPR-567-7210K
Key Blank	SPR-567-7320K
Draw Slide	SPR-567-7050K
Castors	SPR-567-6900K
Top Mat	SPR-567-7560K
Draw Liner	SPR-567-6610K

For Prices see Page 536

Colour	Width (mm)	Depth (mm)	Height (mm)	Weight each	Order Code
Red	680	435	660	26kg	-1030K

5 Drawer

Drawer sizes (W x D x H):

- 3 @ 511 x 403 x 75mm.
- 2 @ 551 x 403 x 155mm.



Spares	Order Code
Lock	SPR-567-7210K
Key Blank	SPR-567-7320K
Draw Slide	SPR-567-7050K
Castors	SPR-567-6900K
Top Mat	SPR-567-7560K
Draw Liner	SPR-567-6610K

For Prices see Page 536

Colour	Width (mm)	Depth (mm)	Height (mm)	Weight each	Order Code
Red	680	435	660	33kg	-1050K

GROUP 594 ROLLER CABINETS & TOOL CHESTS

SENATOR QUALITY TOOLING 6 Drawer Tool Chest & 7 Drawer Roller Cabinet



6 Drawer Tool Chest

Body made from 0.8mm steel panels with 0.6mm drawers. Epoxy powder coated finish in blue/grey with chrome finished PVC drawer pulls. The fully locking fold down lid encloses the six drawers which have foam liners and quick release smooth running 250mm ball bearing drawer slides. Supplied with a loose tote tray for carrying tools to work area. Strong chrome carrying handles. Drawer loads should be evenly distributed.

Overall Dimensions (W x D x H): 668 x 315 x 389mm.

Top Compartment (W x D x H): 660 x 305 x 50mm.

Tote Tray (W x D x H): 430 x 170 x 45mm.

Drawer Sizes (W x D x H):

1@ 590 x 279 x 101.5mm, 2@ 590 x 279 x 49mm, 1@ 281 x 279 x 49mm, 2@ 127 x 279 x 49mm.

7 Drawer Roller Cabinet

Body made from 1mm steel panels with 0.8mm drawers. Epoxy powder coated finish in blue/grey with chrome finished PVC drawer pulls. Fully opening drawers for extra accessibility. Quick release smooth running 350mm ball bearing drawer slides. Supplied with rubber top mat and foam drawer liners. Fully locking. 100 x 25mm hard wearing heavy duty castors, fitted with two brakes. Strong 450mm wide handle. Drawer loads should be evenly distributed. Roller cabinets are not suitable for frequent re-location when loaded and should only ever be pushed.

Overall Dimensions (W x D x H):

689 - 760 with handle x 459 x 780mm - 915 with castors.

Drawer Sizes (W x D x H):

4@ 590 x 409 x 49mm, 2@ 590 x 409 x 101.5mm, 1@ 590 x 409 x 206.5mm.



Description	Colour	Weight each	Order Code
6 Drawer Tool Chest	Blue/Grey		SEN-594
7 Drawer Tool Cabinet			-5240K -5580K

YAMOTO 6 Drawer Tool Chest & 7 Drawer Roller Cabinet



6 Drawer Tool Chest

Body made from 0.8mm steel panels with 0.6mm drawers. Epoxy powder coated finish in yellow/grey with aluminium drawer pulls. The fully locking fold down lid encloses the six drawers which have foam liners and quick release smooth running 250mm ball bearing drawer slides. Supplied with a loose tote tray for carrying tools to work area. Strong chrome carrying handles. Drawer loads should be evenly distributed.

Overall Dimensions (W x D x H): 668 x 315 x 389mm.

Top Compartment (W x D x H): 660 x 305 x 50mm.

Tote Tray (W x D x H): 430 x 170 x 45mm.

Drawer Sizes (W x D x H):

1@ 590 x 279 x 101.5mm, 2@ 590 x 279 x 49mm, 1@ 281 x 279 x 49mm, 2@ 127 x 279 x 49mm.

7 Drawer Roller Cabinet

Body made from 1mm steel panels with 0.8mm drawers. Epoxy powder coated finish in yellow/grey with aluminium drawer pulls. Fully opening drawers for extra accessibility. Quick release smooth running 350mm ball bearing drawer slides. Supplied with rubber top mat and foam drawer liners. Fully locking. 100 x 25mm hard wearing heavy duty castors, fitted with two brakes. Strong 450mm wide handle. Drawer loads should be evenly distributed. Roller cabinets are not suitable for frequent re-location when loaded and should only ever be pushed.

Overall Dimensions (W x D x H):

689 - 760 with handle x 459 x 780mm - 915 with castors.

Drawer Sizes (W x D x H):

4@ 590 x 409 x 49mm, 2@ 590 x 409 x 101.5mm, 1@ 590 x 409 x 206.5mm.



Description	Colour	Weight each	Order Code
6 Drawer Tool Chest	Yellow/Grey		YMT-594
7 Drawer Tool Cabinet			-5240K -5580K

Hand Tools



YAMOTO Roller Cabinets

Steel panels with double wall construction side panels and welded joints for added rigidity. Hard wearing epoxy powder coating. Solid one piece I-beam drawer slides with double sliders on base drawer. Supplied with top mat and drawer liners. Fully locking. 100mm rubber castors, fitted with two brakes. Overall dimensions: 850 x 690 x 460mm. Castors are rated to 40kg capacity standing load per castor. Drawer loads should be evenly distributed. Roller cabinets are not suitable for frequent re-location when loaded, and when moved should only ever be pushed.

3 Drawer

Bottom compartment

(W x D x H):

610 x 430 x 355mm.

Drawer sizes (W x D x H):

3 @ 590 x 410 x 100mm.

Uses 16" drawer slides.



Spares	Order Code
Lock	SPR-567-7210K
Key Blank	SPR-567-7320K
Draw Slide	SPR-567-7050K
Castors	SPR-567-6900K
Top Mat	SPR-567-7560K
Draw Liner	SPR-567-6610K

For Prices see Page 536

Colour	Width (mm)	Depth (mm)	Height (mm)	Weight each	Order Code
Red	690	460	850	43kg	-0500K

5 Drawer

Internal drawer dimensions

(W x D x H):

4 @ 590 x 410 x 100mm.

1 @ 590 x 410 x 200mm.

Uses 16" drawer slides.



For Spares see Page 536



Spares	Order Code
Lock	SPR-567-7210K
Key Blank	SPR-567-7320K
Draw Slide	SPR-567-7050K
Castors	SPR-567-6900K
Top Mat	SPR-567-7560K
Draw Liner	SPR-567-6610K

For Prices see Page 536

Colour	Width (mm)	Depth (mm)	Height (mm)	Weight each	Order Code
Red	690	460	850	46.5kg	-0540K

7 Drawer

Internal drawer dimensions

(W x D x H):

4 @ 590 x 410 x 50mm.

2 @ 590 x 410 x 100mm.

1 @ 590 x 410 x 200mm.

Uses 16" drawer slides.



Spares	Order Code
Lock	SPR-567-7210K
Key Blank	SPR-567-7320K
Draw Slide	SPR-567-7050K
Castors	SPR-567-6900K
Top Mat	SPR-567-7560K
Draw Liner	SPR-567-6610K

For Prices see Page 536

Colour	Width (mm)	Depth (mm)	Height (mm)	Weight each	Order Code
Red	690	460	850	52.5kg	-0580K

Tool Chests

Supplied with tote tray. Piano hinge and lid stays.

3 Drawer

Drawer sizes (W x D x H):

1 @ 590 x 285 x 50mm.

2 @ 590 x 285 x 100mm.

Top compartment

size:

660 x 150

x 90mm.

Uses 10"

Drawer

slides.

Type A lid

stays.



Spares Order Code

Lock	SPR-567-7240K
Key Blank	SPR-567-7320K
Draw Slide	SPR-567-7020K
Lid Stays	SPR-567-6950K
Draw Liner	SPR-567-6610K

For Prices see Page 536

Colour	Width (mm)	Depth (mm)	Height (mm)	Weight each	Order Code
Red	670	315	385	27kg	-0200K

6 Drawer

Carry handles. All steel construction. Supplied with drawer liners.

Drawer sizes (W x D x H):

2 @ 130 x 285 x 50mm.

1 @ 280 x 285 x 50mm.

2 @ 590 x 285 x 50mm.

1 @ 590 x 285 x 100mm.

Top compartment

size (W x D x H):

660 x 150 x 90mm.

Uses 10" drawer slides.

Type A lid stays.



Spares Order Code

Lock	SPR-567-7240K
Key Blank	SPR-567-7320K
Draw Slide	SPR-567-7020K
Lid Stays	SPR-567-6950K
Draw Liner	SPR-567-6610K

For Prices see Page 536

Colour	Width (mm)	Depth (mm)	Height (mm)	Weight each	Order Code
Red	670	315	385	27kg	-0240K

12 Drawer

Double thickness side walls.

One piece drawer slides. Epoxy powder coated finish.

Drawer sizes (W x D x H):

8 @ 130 x 410 x 50mm.

1 @ 280 x 410 x 100mm.

2 @ 590 x 410 x 50mm.

1 @ 590 x 410 x 100mm.

Top compartment

size (W x D x H):

660 x 150 x 90mm.

Uses 10" drawer slides.

Type A lid stays.



Spares Order Code

Lock	SPR-567-7240K
Key Blank	SPR-567-7320K
Draw Slide	SPR-567-7020K
Lid Stays	SPR-567-6950K
Draw Liner	SPR-567-6610K

For Prices see Page 536

Colour	Width (mm)	Depth (mm)	Height (mm)	Weight each	Order Code
Red	670	445	490	47kg	-0280K

GROUP 594 ROLLER CABINETS & TOOL CHESTS

KENNEDY Step-up PROFESSIONAL Units

2 Drawer

Manufactured from heavy gauge steel. electro-coated enamel finish for superior appearance and protection. Steel panels in the drawers for extra rigidity, ball bearing drawer runners. Supplied with drawer liners and top mat.

Drawer sizes (W x D x H):

2 @ 590.5 x 410 x 102mm.



Spares	Order Code
Lock	SPR-567-7210K
Key Blank	SPR-567-7320K
Draw Slide	SPR-567-7040K
Top Mat	SPR-567-7560K
Draw Liner	SPR-567-6610K

For Prices see Page 536

Colour	Width (mm)	Depth (mm)	Height (mm)	Weight each	Order Code KEN-594
Red	688	459	280	44.0kg	-5400K
Green					-5410K

Tool Chests

3 Drawer

Top compartment size:

90 x 660 x 150mm.

Drawer sizes (W x D x H):

1 @ 590 x 285 x 50mm.
2 @ 590 x 285 x 100mm.



Spares	Order Code
Lock	SPR-567-7240K
Key Blank	SPR-567-7320K
Draw Slide	SPR-567-7000K
Lid Stays	SPR-567-6950K
Draw Liner	SPR-567-6610K

For Prices see Page 536

Colour	Width (mm)	Depth (mm)	Height (mm)	Weight each	Order Code KEN-594
Red	690	315	385	44.0kg	-5200K
Green					-5210K

6 Drawer

Top compartment size:

660 x 150 x 90mm.

Drawer sizes (W x D x H):

2 @ 125 x 285 x 50mm.
1 @ 280 x 285 x 50mm.
2 @ 590 x 285 x 50mm.
1 @ 590 x 285 x 100mm.



Spares	Order Code
Lock	SPR-567-7240K
Key Blank	SPR-567-7320K
Draw Slide	SPR-567-7000K
Lid Stays	SPR-567-6950K
Draw Liner	SPR-567-6610K

For Prices see Page 536

Colour	Width (mm)	Depth (mm)	Height (mm)	Weight each	Order Code KEN-594
Red	690	315	385	44.0kg	-5240K
Green					-5250K

12 Drawer

Top compartment size (W x D x H):

660 x 150 x 90mm.

Drawer sizes (W x D x H):

6 @ 125 x 410 x 50mm.
1 @ 170 x 410 x 155mm.
2 @ 130 x 410 x 75mm.
2 @ 590 x 410 x 50mm.
1 @ 590 x 410 x 100mm.



Uses 14" drawer slides. Type B lid stays.

EXTRA DEEP

Spares	Order Code
Lock	SPR-567-7240K
Key Blank	SPR-567-7320K
Draw Slide	SPR-567-7040K
Lid Stays	SPR-567-6950K
Draw Liner	SPR-567-6610K

For Prices see Page 536

Colour	Width (mm)	Depth (mm)	Height (mm)	Weight each	Order Code KEN-594
Red	690	445	490	48.0kg	-5280K
Green					-5290K

Extra Deep Tool Chests

5 Drawer

Over 25% deeper than standard size toolchests for extra storage.

Drawer sizes (W x D x H):

3 @ 595 x 405 x 50mm.
2 @ 595 x 405 x 100mm.



Uses 14" drawer slides. Type B lid stays.

EXTRA DEEP

Spares	Order Code
Lock	SPR-567-7240K
Key Blank	SPR-567-7320K
Draw Slide	SPR-567-7060K
Lid Stays	SPR-567-6960K
Draw Liner	SPR-567-6610K

For Prices see Page 536

Colour	Width (mm)	Depth (mm)	Height (mm)	Weight each	Order Code KEN-594
Red	660	405	510		-5340K

9 Drawer

Over 25% deeper than standard size toolchests for extra storage.

Drawer sizes (W x D x H):

6 @ 295 x 405 x 50mm.
1 @ 595 x 405 x 50mm.
2 @ 595 x 405 x 100mm.



Uses 14" drawer slides. Type B lid stays.

EXTRA DEEP

Spares	Order Code
Lock	SPR-567-7240K
Key Blank	SPR-567-7320K
Draw Slide	SPR-567-7060K
Lid Stays	SPR-567-6960K
Draw Liner	SPR-567-6610K

For Prices see Page 536

Colour	Width (mm)	Depth (mm)	Height (mm)	Weight each	Order Code KEN-594
Red	660	405	510		-5360K

Hand Tools

KENNEDY Professional Roller Cabinets



Manufactured from heavy gauge steel with double wall construction side panels and welded joints for added rigidity. Coated in a hard wearing epoxy powder. Fully opening drawers for extra accessibility. Quick release smooth running ball bearing drawer slides with double sliders on base drawer. Supplied with top mat and drawer liners. Fully locking. 125 x 50mm heavy duty extra strong castors, fitted with two brakes. Overall dimensions: 890 x 690 x 460mm. Castors are rated to 100kg capacity standing load per castor. Drawer loads should be evenly distributed. Roller cabinets are not suitable for frequent re-location when loaded, and when moved should only ever be pushed.

3 Drawer

Internal drawer dimensions bottom compartment (W x D x H):
610 x 430 x 355mm.

Drawers (W x D x H):
3 @ 590 x 410 x 100mm.

Uses 16" drawer slides.



Spares	Order Code
Lock	SPR-567-7260K
Key Blank	SPR-567-7320K
Draw Slide	SPR-567-7040K
Castors	SPR-567-6920K
Top Mat	SPR-567-7560K
Draw Liner	SPR-567-6610K

For Prices see Page 536

5 Drawer

Drawers (W x D x H):
4 @ 590 x 410 x 100mm.
1 @ 590 x 410 x 200mm.
Uses 16" drawer slides.



Spares	Order Code
Lock	SPR-567-7210K
Key Blank	SPR-567-7320K
Draw Slide	SPR-567-7040K
Castors	SPR-567-6920K
Top Mat	SPR-567-7560K
Draw Liner	SPR-567-6610K

For Prices see Page 536

Colour	Width (mm)	Depth (mm)	Height (mm)	Weight each	Order Code
Red	690	460	890	44.0kg	KEN-594 -5500K
Green	690	460	890	44.0kg	-5510K

Colour	Width (mm)	Depth (mm)	Height (mm)	Weight each	Order Code
Red	690	460	890	44.0kg	KEN-594 -5540K
Green	690	460	890	44.0kg	-5550K

7 Drawer

Drawers (W x D x H):
4 @ 590 x 410 x 50mm.
2 @ 590 x 410 x 100mm.
1 @ 590 x 410 x 200mm.

Uses 16" drawer slides.



Spares	Order Code
Lock	SPR-567-7210K
Key Blank	SPR-567-7320K
Draw Slide	SPR-567-7040K
Castors	SPR-567-6920K
Top Mat	SPR-567-7560K
Draw Liner	SPR-567-6610K

For Prices see Page 536

Colour	Width (mm)	Depth (mm)	Height (mm)	Weight each	Order Code
Red	690	460	890	53.0kg	KEN-594 -5580K
Green	690	460	890	53.0kg	-5590K

Tool Box on Wheels

Steel lid stay prevents accidental closure. Heavy duty side handles with 90° stop to prevent hand injury. Full width drawers with one piece drawer slides, allow the drawers to be fully extended. Heavy duty 125mm castors - two fixed and two swivel, steel steering rod with cushion grip, allows the tool box to be easily moved around even when fully loaded. The lid is reinforced to allow it to be used for standing on.

Warning: the castor brake must be applied and the lid closed before using as a "step-up".



Overall Dimensions:
W665 x D305 x H370.
Top compartment size:
660 x 300 x 120mm.
Drawer sizes:
2 @ 575 x 275 x 40mm;
1 @ 575 x 275 x 60mm.

Overall Length	Overall Width	Overall Depth	Weight each	Order Code
660mm	305mm	520mm	34.0kg	KEN-594 -3010K

GROUP 594 ROLLER CABINETS & TOOL CHESTS

KENNEDY Extra Large Tool Chests & PROFESSIONAL Roller Cabinets

Manufactured from heavy gauge steel with double wall construction side panels and welded joints for added rigidity. Coated in a hard wearing epoxy powder. Fully opening drawers for extra accessibility. Quick release smooth running ball bearing drawer slides. Supplied with top mat and drawer liners. Fully locking. 125 x 50mm heavy duty extra strong castors, fitted with two brakes. Castors are rated to 100kg capacity standing load per castor. Drawer loads should be evenly distributed. Roller cabinets are not suitable for frequent re-location when loaded and should only ever be pushed.

11 Drawer Top Chest

Top compartment (W x D x H): 1020 x 390 x 100mm.

Drawer sizes (W x D x H):

5 @ 580 x 415 x 50mm. 1 @ 580 x 415 x 100mm.
4 @ 270 x 415 x 50mm. 1 @ 270 x 415 x 150mm.



Spares	Order Code
Lock	SPR-567-7240K
Key Blank	SPR-567-7320K
Draw Slide	SPR-567-7040K
Lid Stays	SPR-567-6970K
Top Mat	SPR-567-6780K
Draw Liner	SPR-567-6610K

For Prices see Page 536

Colour	Width (mm)	Depth (mm)	Height (mm)	Weight each	Order Code
Red	1030	460	530	94.0kg	KEN-594 -5780K

7 Drawer Roller Cabinet

Internal drawer dimensions

Bottom compartment (W x D x H):

400 x 460 x 300mm.

400 x 460 x 415mm

Drawer sizes (W x D x H):

4 @ 580 x 415 x 50mm. 2 @ 580 x 415 x 100mm. 1 @ 580 x 415 x 150mm.

Uses 14" drawer slides.

Type B lid stays.



EXTRA LARGE

Spares	Order Code
Lock	SPR-567-7260K
Key Blank	SPR-567-7320K
Draw Slide	SPR-567-7040K
Castors	SPR-567-6920K
Top Mat	SPR-567-7520K
Draw Liner	SPR-567-6610K

For Prices see Page 536

Colour	Width (mm)	Depth (mm)	Height (mm)	Weight each	Order Code
Red	1060	480	925	81.0kg	KEN-594 -5700K

11 Drawer Roller Cabinet

Drawer sizes (W x D x H):

4 @ 270 x 415 x 50mm.

4 @ 560 x 415 x 50mm.

2 @ 560 x 415 x 100mm.

1 @ 560 x 415 x 170mm.

Uses 14" drawer slides.

Type B lid stays.



For Spares see Page 536



Spares	Order Code
Lock	SPR-567-7210K
Key Blank	SPR-567-7320K
Draw Slide	SPR-567-7040K
Castors	SPR-567-6920K
Top Mat	SPR-567-7540K
Draw Liner	SPR-567-6610K

For Prices see Page 536

EXTRA LARGE

Colour	Width (mm)	Depth (mm)	Height (mm)	Weight each	Order Code
Red	680	480	1130	83.0kg	KEN-594 -5740K

Magnetic Tool Tray

Steel tool/parts tray with durable hardwearing corrosion-resistant powder coated finish. Suitable for keeping small parts, components and tools near to hand when working on vehicles, domestic appliances and other equipment. Three high strength magnets in protective non-scratch rubber coating.



Length x Width x Depth (mm)	Weight each	Order Code
210 x 115 x 115		KEN-594 -6500K
310 x 115 x 115		-6520K

Hand Tools

KENNEDY Extra Heavy Duty PROFESSIONAL Tool Chest

4 Drawer + Top compartment

Heavy gauge steel, welded and riveted to form an extremely rigid construction. The two part epoxy powder paint finish gives excellent corrosion resistance and ensures durability. The central locking system automatically locks the closed drawers when the lid is lowered to give good security. A full width piano hinge provides rigidity, strength and additional security. The drawers have smooth running ball bearing drawer slides and each drawer has its own safety catch to prevent accidental opening. The Four full-length drawers have rigid aluminium edged handles and are sized:

Drawer sizes (W x D x H):

- 2 @ 560 x 340 x 40mm
- 1 @ 560 x 340 x 65mm
- 1 @ 560 x 340 x 95mm

Width (mm)	Depth (mm)	Height (mm)	Weight each	Order Code KEN-594
715	415	450	35.5kg	-4820K

Extra Large, Extra Heavy Duty Tool Chest

9 Drawer + Top compartment

Heavy gauge steel, welded and riveted to form this extra large chest. Corrosion resistant powder coated finish provides superb durability. The locking mechanism locks all drawers as the lid is closed and each drawer has its own safety catch to prevent accidental opening for added security. Four heavy duty type carry handles with comfortable grips for easier lifting. The lid has a full width piano hinge giving extra rigidity, strength and additional security. Drawers have smooth running ball bearing drawer slides and rigid aluminium edged handles.

Drawer sizes (W x D x H):

- 2 @ 560 x 340 x 40mm
- 2 @ 560 x 340 x 65mm
- 1 @ 560 x 340 x 95mm
- 2 @ 305 x 340 x 40mm
- 1 @ 305 x 340 x 65mm
- 1 @ 305 x 340 x 180mm

Width (mm)	Depth (mm)	Height (mm)	Weight each	Order Code KEN-594
1090	450	530	68kg	-4860K



For Chest and Cabinet Spares refer to table on page 536

Features of our XD and XDXL range

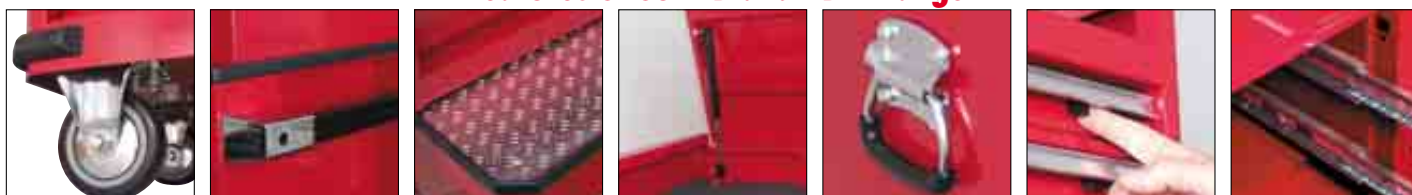

HD Castors HD Side Handle Checker-plate Top Gas Strut HD Chest Handles Individual Catches Ball Bearing Slides

Extra Heavy Duty Roller Cabinet — 7 Drawer

Heavy gauge steel, welded and riveted to give an extremely rigid construction. Corrosion resistant powder coated finish provides superb durability. Locking mechanism locks all the closed drawers which have individual safety catches to prevent accidental opening. Four heavy duty castors, two fixed and two swivel which when combined with the heavy duty side handle enable the user to move it with ease. All drawers have smooth running ball bearing drawer slides and aluminium edged handles.

Drawer sizes (W x D x H):

- 1 @ 560 x 390 x 40mm
- 4 @ 560 x 390 x 65mm
- 1 @ 560 x 390 x 95mm
- 1 @ 560 x 390 x 205mm

Width (mm)	Depth (mm)	Height (mm)	Weight each	Order Code KEN-594
740	460	995	71.5kg	-4840K

Extra Large, Extra Heavy Duty Roller Cabinet

13 Drawer

Heavy gauge steel, welded and riveted to give extremely rigid construction. The two part epoxy powder paint finish gives excellent corrosion resistance and ensures durability. The central locking system locks all the closed drawers which have individual safety catches. The heavy duty castors and side handle are designed to cope with the extra large size and weight. Drawers have smooth running ball bearing drawer slides and rigid aluminium edged handles.

Drawer sizes (W x D x H):

- 2 @ 560 x 390 x 95mm
- 4 @ 560 x 390 x 65mm
- 1 @ 560 x 390 x 205mm
- 1 @ 305 x 390 x 95mm
- 3 @ 305 x 390 x 65mm
- 1 @ 305 x 390 x 180mm
- 1 @ 305 x 390 x 205mm

Width (mm)	Depth (mm)	Height (mm)	Weight each	Order Code KEN-594
1115	460	1050	119.5kg	-4880K

PRODUCTS ARE ONLY AVAILABLE VIA YOUR DISTRIBUTOR

Hand Tools

GROUP 594 ROLLER CABINETS & TOOL CHESTS

KENNEDY Stainless Steel PROFESSIONAL Tool Chest

Manufactured from heavy gauge stainless steel with double wall construction side panels and welded joints for added rigidity. Quick release smooth running ball bearing drawer slides. Fully locking. Drawer loads should be evenly distributed. Suitable for use in health and catering environments.

4 Drawer
Drawer sizes (W x D x H):
 4 @ 597x 428 x 90mm.

For Spares see below



Spares	Order Code
Lock	SPR-567-7210K
Key Blank	SPR-567-7320K
Draw Slide	SPR-567-7040K
Draw Liner	SPR-567-6610K

For Prices see Below

Width (mm)	Depth (mm)	Height (mm)	Weight each	Order Code KEN-594
673	470	513	44kg	-1540K



Stainless Steel Roller Cabinet

Manufactured from heavy gauge stainless steel with double wall construction side panels and welded joints for added rigidity. Quick release smooth running ball bearing drawer slides. Fully locking. 125 x 50mm heavy duty extra strong castors, fitted with two brakes. Castors are rated to 100kg capacity standing load per castor. Drawer loads should be evenly distributed. Roller cabinets are not suitable for frequent re-location when loaded and should only ever be pushed. Suitable for use in health and catering environments.

7 Drawer
Drawer sizes (W x H x H):
 5 @ 597 x 428 x 90mm.
 1 @ 597 x 428 x 135mm.
 1 @ 597 x 428 x 180mm.

Spares	Order Code
Lock	SPR-567-7210K
Key Blank	SPR-567-7320K
Draw Slide	SPR-567-7040K
Castors	SPR-567-6920K
Top Mat	SPR-567-7540K
Draw Liner	SPR-567-6610K







For Prices see Below

Width (mm)	Depth (mm)	Height (mm)	Weight each	Order Code KEN-594
683	480	887	72kg	-6020K



Cabinet & Chest Spares

* Note: Draw liner size is 583 x 405mm and can be cut to size.

							
Cabinet/Chest Order Code	Order Code SPR-567	Order Code SPR-567	Order Code SPR-567	Order Code SPR-567	Order Code SPR-567	Order Code SPR-567	Order Code SPR-567
KENNEDY							
KEN-594-1540K	-7210K	-7320K	-	-	-	-	-6610K
KEN-594-4820K	-	-7320K	-	-	-	-	-6610K
KEN-594-4840K	-7210K	-7320K	-	-	-	-	-6610K
KEN-594-4860K	-	-7320K	-	-	-	-	-6610K
KEN-594-4880K	-7210K	-7320K	-	-	-	-	-6610K
KEN-594-5200K	-	-7320K	-	-	-	-	-6610K
KEN-594-5210K	-	-7320K	-	-	-	-	-6610K
KEN-594-5240K	-	-7320K	-	-	-	-	-6610K
KEN-594-5250K	-	-7320K	-	-	-	-	-6610K
KEN-594-5280K	-	-7320K	-	-	-	-	-6610K
KEN-594-5290K	-	-7320K	-	-	-	-	-6610K
KEN-594-5340K	-	-7320K	-	-	-	-	-6610K
KEN-594-5360K	-	-7320K	-	-	-	-	-6610K
KEN-594-5400K	-7210K	-7320K	-	-	-	-7560K	-6610K
KEN-594-5410K	-7210K	-7320K	-	-	-	-7560K	-6610K
KEN-594-5500K	-	-7320K	-	-	-	-7560K	-6610K
KEN-594-5510K	-	-7320K	-	-	-	-7560K	-6610K
KEN-594-5540K	-7210K	-7320K	-	-	-	-7560K	-6610K
KEN-594-5550K	-7210K	-7320K	-	-	-	-7560K	-6610K
KEN-594-5580K	-7210K	-7320K	-	-	-	-7560K	-6610K
KEN-594-5590K	-7210K	-7320K	-	-	-	-7560K	-6610K
KEN-594-5700K	-	-7320K	-	-	-	-	-6610K
KEN-594-5740K	-7210K	-7320K	-	-	-	-	-6610K
KEN-594-5780K	-	-7320K	-	-	-	-	-6610K
KEN-594-6020K	-7210K	-7320K	-	-	-	-	-6610K
SENATOR QUALITY TOOLING							
SEN-594-0200K	-	-	-	-	-	-	-6610K
SEN-594-0240K	-	-7320K	-	-	-	-	-6610K
SEN-594-0580K	-7210K	-7320K	-	-	-	-7560K	-6610K
SEN-594-1030K	-7210K	-7320K	-	-	-	-7560K	-6610K
SEN-594-1050K	-7210K	-7320K	-	-	-	-7560K	-6610K
YAMOTO							
YMT-594-0200K	-	-7320K	-	-	-	-	-6610K
YMT-594-0240K	-	-7320K	-	-	-	-	-6610K
YMT-594-0280K	-	-7320K	-	-	-	-	-6610K
YMT-594-0500K	-7210K	-7320K	-	-	-	-7560K	-6610K
YMT-594-0540K	-7210K	-7320K	-	-	-	-7560K	-6610K
YMT-594-0580K	-7210K	-7320K	-	-	-	-7560K	-6610K

**Available on request
 Please contact
 your local
 distributor for
 details**

Hand Tools



YAMOTO Starter Mechanic's Tool Kit - 100 pieces

- 8" & 12" satin chrome adjustable wrench set.
- 5m/16ft locking tape rule.
- Lightweight hacksaw frame.
- 400cc lever type steel grease gun.
- 150mm long nose pliers.
- 200mm long nose pliers.
- 150mm diagonal nippers.
- 150mm linesmans combination pliers.
- 200mm linesmans combination pliers.
- 250mm waterproof pliers.
- 12 piece mechanics pattern screwdriver set.
- 7 piece 6 - 19mm chrome vanadium open ended spanner set.
- 14 piece 6 - 19mm chrome vanadium combination spanner set.
- 55 piece 3/8" drive socket and bit set.
- 6 drawer red tool chest.

**100
PIECES**



Set contents may vary slightly according to product development and availability.

Number of Pieces	Weight each	Order Code
100	34.0kg	YMT-595 -3500K

SENATOR 90 Piece Engineer's Workshop Tool Kit
QUALITY TOOLING

- Top chest
- 24 piece 1/2" drive metric socket set
- 6 Piece 16cm cut 2 assorted needle file set
- 10x 12" x 1/2"x 18tpi All hard hacksaw blades
- 8"/200mm Chrome vanadium adjustable spanner
- 12" Rule - walleded
- Metric/inch feeler gauge 60mm blade length
- 1 1/2lb Ball pein hammer- hickory shaft
- 16oz Black rubber mallet - wood shaft
- 5m/16ft Locking tape rule - chromed case
- 8 seg 18mm Heavy duty snap-off blade knife
- Retractable trimming knife
- DIY hacksaw
- 2x 50mm G clamps
- 2x 100mm G clamps
- 6" Snipe nose plier/side cutter
- 8" Straight blade tinsnip
- 6" Diagonal cutting nipper
- 7" Linesman plier
- 10" Multiple slip joint plier
- 10" Straight jaw high strength grip wrench
- Multi function plier
- 16 Function 10-blade tool
- 12 Piece fluted handle screwdriver set
- 14 Piece 6-19mm drop forged combination spanner set

**90
PIECES**



Set contents may vary slightly according to product development and availability.

Number of Pieces	Weight each	Order Code
90		SEN-595 -1000K

PRODUCTS ARE ONLY AVAILABLE VIA YOUR DISTRIBUTOR

Hand Tools

GROUP 595 TOOL KITS

KENNEDY 300 Piece Engineers Professional Professional Tool Kit

Supplied in a 5 drawer professional roller cabinet and a 3 drawer top chest. Manufactured from heavy gauge steel with double wall construction side panels and welded joints for added rigidity. Coated in a hard wearing epoxy powder. Fully opening drawers for extra accessibility. Quick release smooth running ball bearing drawer slides with double sliders on base drawer. Supplied with top mat and drawer liners. Fully locking. 125 x 50mm heavy duty extra strong castors, fitted with two brakes. Overall dimensions: 890 x 690 x 460mm. Castors are rated to 100kg capacity standing load per castor. Drawer loads should be evenly distributed.

3 drawer top chest.

Top compartment size: 89 x 661 x 150mm.
 Drawer sizes: 1 @ 51 x 591 x 282.5mm,
 2 @ 102 x 591 x 282.5mm.

5 drawer roller cabinet, internal drawer dimensions:

Drawers: 4 @ 591 x 460 x 102mm.
 Drawers: 1 @ 591 x 410 x 204mm.

Contents:

- Set of 25 HSS Drills 1 - 13.00mm x 0.5mm.
- 8 Piece 200mm (8") double cut engineers file set.
- 16cm (6½") cut 2 assorted needle file set.
- 20x 150mm (6") Junior hacksaw blades.
- 10x 12" x ½" x 18TPI HSS all hard hacksaw blade.
- 25x 230mm x 280mm Assorted abrasive sheets.
- 200mm (8") Soft grip phosphate adjustable wrench.
- 6x 150mm flat cold chisels.
- 3" 18-bld. Met/imp comb feeler gauge set.
- 4" x ¾" (4.8mm) square head centre punch.
- Set of 6 parallel pin punches.
- 150mm/6" imp/metric rigid rustless rule.
- 300mm/12" rigid rustless rule - round end.
- 150mm (6") engineers square.
- 300mm (12") engineers square.
- 7" Double ended engineers scriber.
- 1¼" Focal length eye loupe.
- Adjustable telescopic 1¼" mirror.
- Set of 2: ¼" - ¼" & ¼" - ¾" tap wrenches.
- 1lb ball pein hammer - wood shaft.
- 16oz black rubber mallet - wood shaft.
- 5½" Plastic handle household scissors.
- 8½" Plastic handle household scissors.
- 5m/16" Professional ABS steel tape.
- Snap-off 8 seg-blade heavy duty economy knife.
- Retractable trimming knife c/w 5 blades.
- Beaver style junior hacksaw.
- Professional 'plus' cushion grip hacksaw.
- Magnetic pick-up tool.
- Set of 4 Pro-Torq pliers.
- 10" Ideal grip wrench.
- 12 piece Pro-Torq screwdriver set.
- 64 Piece ¼" hexagon bit set.
- ¼" hex bit driver.
- 7 Piece box spanner set 6-19mm c/w tommy bars.
- Combination wrenches: 10, 11, 12, 13, 14, 15, 16, 17, 18 and 19mm.
- 50 Piece metric ¾" square drive socket set.
- 8" Straight blade tinsnip.
- 3 Drawer professional tool chest.
- 5 Drawer professional roller cabinet.
- 8 Piece Metric Pro-Torq hex wrench set on clip.
- 9 Piece Inch Pro-Torq hex wrench set on clip.
- 19mm x 33m Black PVC insulation tape.

Set contents may vary slightly according to product development and availability.

Number of Pieces	Weight each	Order Code
300		KEN-595 -3080K

300
PIECES

NEW



Hand Tools



KENNEDY 208 Piece Apprentice Engineer's PROFESSIONAL Tool Kit- AET200

**208
PIECES**

Supplied in a three drawer professional roller cabinet and a three drawer top chest. Manufactured from heavy gauge steel with double wall construction side panels and welded joints for added rigidity. Coated in a hard wearing epoxy powder. Fully opening drawers for extra accessibility. Quick release smooth running ball bearing drawer slides with double sliders on base drawer. Supplied with top mat and drawer liners. Fully locking. 125 x 50mm heavy duty extra strong castors, fitted with two brakes. Overall dimensions: 890 x 690 x 460mm. Castors are rated to 100kg capacity standing load per castor. Drawer loads should be evenly distributed.

3 Drawer Top Chest

Top compartment size: 89 x 661 x 150mm.
Drawer sizes: 1 @ 51 x 591 x 282.5mm.
2 @ 102 x 591 x 282.5mm.

3 Drawer Roller Cabinet

Internal Drawer Dimensions

Bottom compartment size: 610 x 432 x 356mm.
Drawer sizes: 3 @ 591 x 410 x 102mm.

Contents:

- 25 piece HSS drill set 1 - 13.00mm x 0.5mm.
- 6 piece 200mm double cut engineer's file set.
- 6 piece 16cm cut 2 assorted needle file set.
- 25 x 230 x 280mm assorted abrasive sheet.
- 200mm chrome vanadium steel adjustable spanner.
- 6 x 150mm flat cold chisel.
- 19mm x 33m black pvc insulation tape.
- 76mm, 18 blade combination feeler gauge set.
- 4.8mm square head centre punch.
- 150mm/6" stainless steel rule c/w pocket clip.
- 178mm double ended engineer's scriber.
- Eye loupe.
- Adjustable telescopic 30mm dia. inspection mirror (expands to 180mm).
- 6 piece parallel pin punch set: 2.4, 3.2, 4.0, 4.8, 5.5 and 6.4mm.
- 150mm/6" engineer's square - **BS 939 grade B.**
- Tap wrenches 1.5 - 6.4mm and 6.4 - 19mm.
- Magnetic telescopic pick-up tool extends to 550mm.
- 29 piece engineer's bit set. All 6mm hex x 25mm overall length, complete with magnetic spinner handle, 6mm hexagon bit adaptor and 6mm square socket adaptor. Hexagon: 2, 3, 4, 5, 6, 7 and 8mm; flat: 3, 4, 5, 5.5, 6.5 and 8mm; $\frac{3}{32}$ ", $\frac{1}{8}$ ", $\frac{5}{32}$ ", $\frac{3}{16}$ ", $\frac{1}{4}$ ", $\frac{7}{32}$ " and $\frac{5}{16}$ "; crosspoint: No.1, 2 and 3; Pozidriv®: No.1, 2 and 3.
- 450g (1lb) ball pein hammer wood shaft.
- 7.5m/25ft steel tape.
- Snap-off 8 segment blade economy knife.
- Retractable trimming knife with 5 blades.
- Junior hacksaw frame.
- 300mm lightweight professional hacksaw frame.
- 6 off 12" x $\frac{1}{2}$ " x 18tpi HSS hacksaw blades.
- 20 junior hacksaw blades.
- 2 plastic handle household scissors.
- 150mm snipe nose plier with side cutter.
- 150mm diagonal cutting nipper.
- 150mm engineers combination pliers with side cutter.
- 250mm curved jaw high strength grip wrench.
- 8 piece Pro-Torq screwdriver set: crosspoint: No.1 x 75, No.2 x 100; pozidriv®: No.2 x 100; flared: 6.3 stubby, 6.3 x 100, 8.0 x 200; parallel: 5.0 x 75, 5.0 x 150.
- 14 piece combination spanner set: 6, 7, 8, 9, 10, 11, 12, 13, 14, 15, 16, 17, 18 and 19mm.
- 25 piece metric socket set $\frac{1}{2}$ " square drive sockets: 8, 9, 10, 11, 12, 13, 14, 15, 16, 17, 18, 19, 22, 24, 27, 30 and 32mm. Spark plug sockets: M10 and M14. Accessories: quick release ratchet handle, sliding T-handle, universal joint, 75, 125 and 250mm extension bars.
- 9 piece metric hex key set 1.5 - 10mm.

Set contents may vary slightly according to product development and availability.

Number of Pieces	Weight each	Order Code
208		KEN-595-0550K



Hand Tools

GROUP 595 TOOL CONTROL

KENNEDY Tool PROFESSIONAL Control

CAD designed and high precision laser cut foam tray inserts are designed to keep tools precisely and accurately in the correct position and drawers for improved productivity. In some applications a dropped tool is a serious hazard, colour contrasting foam inserts are used to easily recognise lost tooling and also reduce audit time.

Areas of use include food industry maintenance, automotive assembly.



25 Piece Set - TCD025

Professional Pliers

- 1x 160mm snipe nose.
- 1x 160mm diagonal cutters.
- 1x 160mm combination.

Pro-Torq Screwdrivers

Crosspoint:

- No.2 x stubby, No.2 x 100mm.

Pozidriv:

- No.1 x 75, No.2 x 100, No.3 x 150mm.

Flared:

- 6.3 x 150, 8.0 x 200mm.

Parallel:

- 5.0 x 150mm.

Metric Professional Combination Wrenches

- 6, 7, 8, 9, 10, 11, 12, 13, 14, 15, 16, 17, 18 and 19mm.



**25
PIECES**

Model Number	Number of Pieces	Weight each	Order Code
TCD025	25	2.3kg	KEN-595 -5000K

Dimensions: 590 x 410 x 45mm

Suitable for Kennedy Toolchests - **KEN- 594-5580K & KEN- 594-5590K**
(see page 1140 for details)

50 Piece Set - TCD050

- 3/8 Sockets:** 6, 7, 8, 9, 10, 11, 12, 13, 14, 15, 16, 17, 18, 19, 20, 21 and 22mm.

Deep Sockets:

- 10, 11, 12, 13, 14, 15, 17, 19 and 22mm.

Screwdriver Bits:

Slotted

- 5, 5.5 and 6.5mm.

Crosspoint

- No.1, 2, 3, and 4.

Hex Bits:

- 3, 4, 5, 6, 8 and 10mm.

Accessories:

- Ratchet handle, sliding T-handle, spinner handle, swivel handle. Universal joint. 125 and 250mm extensions, 250mm wobble extensions, 1/4" and 1/2" male adaptors, 1/4" hex bit coupler.

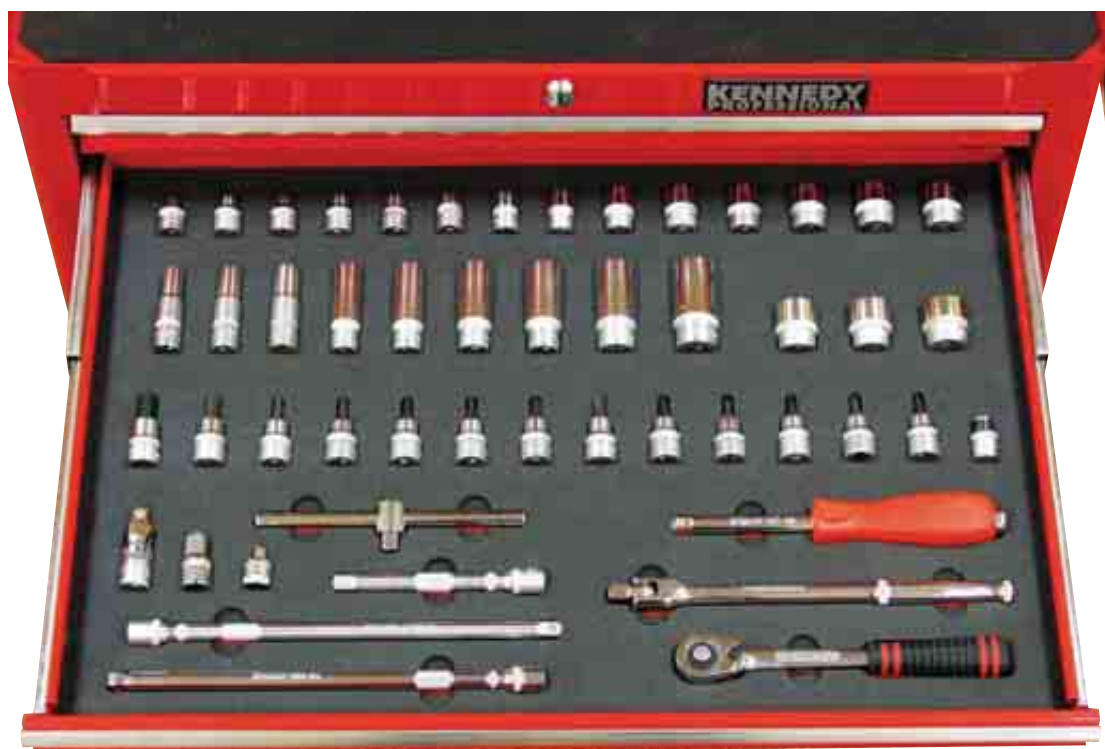

**50
PIECES**

Model Number	Number of Pieces	Weight each	Order Code
TCD055	50	6.2kg	KEN-595 -5020K

Hand Tools



KENNEDY Complete Tool Control Sets include a Kennedy Professional Professional Roller Cabinet

Manufactured from heavy gauge steel with double wall construction side panels and welded joints for added rigidity. Coated in a hard wearing epoxy powder. Fully opening drawers for extra accessibility. Quick release smooth running ball bearing drawer slides with double sliders on base drawer. Supplied with top mat and drawer liners. Fully locking. 125 x 50mm heavy duty extra strong castors, fitted with two brakes. Overall dimensions: 890 x 690 x 460mm. Castors are rated to 100kg capacity standing load per castor. Drawer loads should be evenly distributed.

7 Drawer Roller Cabinet

Drawers (W x D x H): 4 @ 590 x 410 x 50mm. 2 @ 590 x 410 x 100mm. 1 @ 590 x 410 x 200mm.

25 Piece Set Configuration



50 Piece Set Configuration



25 Piece Set With Professional Roller Cabinet

TCC025

Professional Pliers

- 1 x 160mm Snipe nose
- 1 x 160mm diagonal cutters
- 1 x 160mm combination

Metric Professional Combination Wrenches

- 6, 7, 8, 9, 10, 11, 12, 13, 14, 15, 16, 17, 18 & 19mm

Pro-Torq Screwdrivers

- Crosspoint: No.2 x stubby, No.2 x 100mm
- Pozidriv(r): No.1 x 75, No.2 x 100, No.3 x 150mm
- Flared: 6.3 x 150, 8.0 x 200mm
- Parallel: 5.0 x 150mm

25
PIECES



Model Number	No. of Pieces	Weight each	Order Code
TCC025	25	55.3kg	-5540K

50 Piece Set With Professional Roller Cabinet

TCC050

- Sockets:** 6, 7, 8, 9, 10, 11, 12, 13, 14, 15, 16, 17, 18, 19, 20, 21 & 22mm.

- Deep Sockets:** 10, 11, 12, 13, 14, 15, 17, 19 & 22mm.

Screwdriver Bits:

- Slotted:** 5, 5.5 and 6.5mm.
- Crosspoint:** No.1, 2, 3, and 4.
- Hex Bits:** 3, 4, 5, 6, 8 and 10mm.

Accessories:

- Ratchet handle, sliding T-handle, spinner handle, swivel handle.
- Universal joint. 125 and 250mm extensions, 250mm wobble extensions, 1/4" and 1/2" male adaptors, 1/4" hex bit coupler.

50
PIECES



Model Number	No. of Pieces	Weight each	Order Code
TCC050	50	59.2kg	-5520K

75 Piece Set With Professional Roller Cabinet - TCC075

Professional Pliers

- 1 x 160mm Snipe nose
- 1 x 160mm diagonal cutters
- 1 x 160mm combination.

Metric Professional Combination Wrenches

- 6, 7, 8, 9, 10, 11, 12, 13, 14, 15, 16, 17, 18 & 19mm

75
PIECES

Pro-Torq Screwdrivers

Crosspoint - No.2 x stubby, No.2 x 100mm.

Pozidriv(r) - No.1 x 75, No.2 x 100, No.3 x 150mm.

Flared - 6.3 x 150, 8.0 x 200mm.

Parallel - 5.0 x 150mm.

Sockets: 6, 7, 8, 9, 10, 11, 12, 13, 14, 15, 16, 17, 18, 19, 20, 21 and 22mm.

Deep Sockets:

10, 11, 12, 13, 14, 15, 17, 19 and 22mm.

Screwdriver Bits:

Slotted: 5, 5.5 and 6.5mm.

Crosspoint: No.1, 2, 3, and 4.

Hex Bits: 3, 4, 5, 6, 8 and 10mm.

Accessories:

- Ratchet handle, sliding T-handle, spinner handle, swivel handle.
- Universal joint. 125 and 250mm extensions, 250mm wobble extensions, 1/4" and 1/2" male adaptors, 1/4" hex bit coupler.



Model Number	No. of Pieces	Weight each	Order Code
TCC075	75	61.5kg	-5500K

GROUP 595 TOOL KITS

KENNEDY 107 Piece Apprentice Engineer's Tool Kit
QUALITY INDUSTRIAL TOOLING



AET107

Contents:

- Toolbox.
- 6 piece Pro-Torq screwdriver set: crosspoint No.1 x 75 and No.2 x 100mm; flared 6.3 x 100 and 8.0 x 250mm; parallel 5 x 100 and 5 x 200mm.
- 6 piece precision screwdriver set: crosspoint PH0 and PH1; parallel 1.4, 2.0, 2.4, and 3.0mm.
- 6 - 19mm 14 piece metric combination spanner set.
- 9 piece metric hex key set: 1.5 - 10mm.
- 8 piece 2nd cut file set: 1 each flat, hand, round, half round, 3 square and square.
- 12 piece 2nd cut needle file set: 1 each hand, flat, knife, round, half round, square, 3 square, crossing, round edge joint, slitting, warding and barrette.
- 2 of each grade 0, 1 and 2 emery sheets.
- 200mm/8" phosphate adjustable wrench.
- 18 blade metric/inch feeler gauge.
- Magnetic pick-up tool extends to 650mm.
- 7.5m/25ft locking tape rule.
- Snap-off blade knife.
- Junior hacksaw • 20 junior hacksaw blades.
- 300mm (12") hacksaw frame.
- 6 hacksaw blades.
- General purpose shears.
- 3 piece professional plier set.
- 255mm straight jaw grip wrench.
- 6mm x 150mm flat cold chisel.
- 1lb ball pein hammer.
- 175mm engineers scriber.
- 30mm diameter inspection mirror (extends to 650mm).
- 150mm (6") engineers square.
- Centre punch.
- 150mm (6") pocket rule.
- 100cc grease gun.
- Eye loupe.

107
PIECES



Number of Pieces	Weight each	Order Code
107	4.2kg	-0500K

SENATOR 110 Piece Power Bit Set
QUALITY TOOLING



Comprehensive multi-purpose power bit set suitable for use with hand and power tools. Features most commonly used accessories for your corded or cordless drill uniquely packaged for easy organisation and storage. Complete with moulded plastic case.

50x 25mm Bits: 14x Slotted: 4mm x3, 5mm x4, 6mm x4, 7mm x3. 11x Crosspoint: No.1 x4, No.2 x4, No.3 x3. 7x Star: T10, T15, T20, T25, T27, T30, T40. 13x Pozzi: No.0, No.1 x5, No.2 x5, No.3 x2. 5x Hex: 2.0, 3.0, 4.0, 5.0, 6.0mm.

10x 50mm Bits: 3x slotted: 5.0, 6.0mm x2. 4x crosspoint: No.1, No.2 x2, No.3. 3x star: T10, T15, T50.

14x Nutdriver: 7x Metric: 5, 6, 7, 8, 9, 10 and 11mm. 7x AF: 3/16", 7/32", 1/4", 9/32", 5/16", 11/32" and 3/8".

1x quick change adaptor, 1x 2.5mm hex key, 1x countersink. 13x HSS fully polished drill with hex shank:

1.5, 2.0, 2.5, 3.0, 3.2, 3.5, 4.0, 4.5, 4.8, 5.0, 5.5, 6.0 and 6.5mm.

4x Drill Stopper: 4, 5, 6 and 8mm.

1x 50mm spade bit extension.

1x bit holder with magnet.

5x 100mm Flat Wood Bits:

10, 13, 16, 19 and 22mm.

4x Masonry Drill with Hex Shank:

4, 5, 6 and 8mm.

5x Woodworking Drill with Hex Shank:

4, 5, 6 and 8mm.

Packaging dimensions (W x H x D):
383 x 213 x 297mm.

110
PIECES



Number of Pieces	Weight each	Order Code
110	1.9kg	-3110K

161 Piece Power Bit Set

Comprehensive multi-purpose power bit set. Features most commonly used accessories for your corded or cordless drill. Suitable for use with hand and power tools. Complete with moulded plastic case. Uniquely packaged for easy organisation and storage. 2 Storage compartments situated in the lid.

Packaging dimensions (W x H x D):
455 x 178 x 297mm
Gross weight: 3.4kg

161
PIECES



Number of Pieces	Weight each	Order Code
161	3.4kg	-3160K

Hand Tools



SENATOR *22 Piece*
QUALITY TOOLING *Plumber's Kit*

Supplied in a robust toolbox c/w double latch.

Contents:

- Tool box.
- 255mm (10") stillson wrench.
- 3 - 22mm capacity tubing cutter.
- 3 - 41mm tube deburrer.
- 9.5 - 32mm basin wrench.
- 300mm girder section spirit level.
- Telescopic inspection mirror.
- Junior hacksaw frame c/w hardened blade.
- Pad saw.
- 255mm groove slip joint waterpump plier.
- 6 piece flat wood bit set 9.5 - 25mm.
- 12mm x 12m PTFE thread sealing tape to **BS6920**.
- 100g fluxite paste.
- Powerflow lead free solder 3.25mm 250g.
- 3 row plastic handle wire scratch brush.
- 450g (1lb) grade 2 wire wool.
- Blow lamp and 2175 gas cartridge.



22
PIECES

Number of Pieces	Weight each	Order Code
22		KEN-595 -4010K

Builder's Construction Tool Kit - 23 pieces

- 9" (225mm) hi-vis magnetic boat level.
- 24" (600mm) hi-vis girder section level.
- 6" london pattern pointing trowel.
- 11" board heel brick trowel.
- 11½" x 4½" plasterers finishing trowel.
- 1½" ball pein hammer with hickory shaft.
- 16oz claw hammer with wooden shaft.
- 3m/10ft hi-vis locking tape with yellow casing.
- 30m/100ft fibre glass measuring tape.
- 13 segment 9mm standard snap-off blade knife.
- Retractable trimming knife.
- 6" diagonal cutting nipper.
- 8" linesmans pliers.
- 8 piece fluted handle screwdriver set.
- 10" straight blade tinsnip.
- 24" canvas tool bag.



23
PIECES

Set contents may vary slightly according to product development and availability.

Number of Pieces	Weight each	Order Code
23	4.2kg	SEN-595 -1500K

PRODUCTS ARE ONLY AVAILABLE VIA YOUR DISTRIBUTOR

Hand Tools

GROUP 595 TOOL KITS

SENATOR 51 Piece Home Handyman Tool Kit
QUALITY TOOLING

**51
PIECES**



HHK51

Supplied in a robust tool box c/w double latch.

Contents:

- Tuff-E Tool Box.
- 8 piece fluted handle screwdriver set: flared 6mm stubby, 3 x 100mm and 8 x 200mm; parallel 3.2 x 75mm and 4 x 150mm; pozidriv No.2 stubby, No.1 x 75mm and No.2 x 100mm.
- 10 piece screwdriver bit set: 6mm quick release hex bit adaptor; flat 3, 4, 5, 6 and 8mm; crosspoint No.0, 1, 2 and 3mm. • 200mm (8") chrome vanadium adjustable spanner.
- 225mm (9") hi-vis magnetic boat level.
- 600mm (24") hi-vis girder section level.
- 150mm mains tester, range 125/250V.
- 19mm x 33m black pvc insulation tape.
- Adjustable telescopic 300mm dia inspection mirror.
- 450g (16oz) claw hammer wood shaft.
- 3M/10ft hi-vis locking tape.
- 13 seg 9mm standard snap-off blade knife.
- Retractable trimming knife c/w 5 blades.
- 150mm (6") junior hacksaw frame c/w hardened blade. • 150mm (6") junior hacksaw blade for metal (10). • 300mm (12") DIY hacksaw frame. • 177mm (7") plastic handle household scissors. • 63mm (2½") half tang filling knife.
- 76mm (3") half tang scraper.
- Magnetic pick-up tool extends to 650mm.
- 150mm (6") linesman's plier. • 125mm (5") snipe nose plier. • 125mm (5") diagonal cutting nipper.
- 255mm (10") straight jaw grip wrench.
- Bradawl. • 415 Piece poly fish type wall plug set.



Set contents may vary slightly according to product development and availability.

Number of Pieces	Weight each	Order Code
51	7kg	SEN-595 -0520K

61 Piece Home Handyman Tool Kit

**61
PIECES**

HHK61

Supplied in a robust toolbox c/w double latch.

Contents:

- Tool box with tote and wheels. • 8 piece fluted handle screwdriver set: flared 6mm stubby, 3 x 100mm and 8 x 200mm; parallel 3.2 x 75mm and 4 x 150mm; posidriv No.2 Stubby, No.1 x 75mm and No.2 x 100mm.
- 10 piece screwdriver bit set: 6mm quick release hex bit adaptor; flat 3, 4, 5, 6, and 8mm; crosspoint No.0, 1, 2, and 3mm. • 18 piece wood, metal and masonry drill set 3, 4, 5, 6, 8 and 10mm bits. • CD12V-KB cordless drill and kitbag.
- 200mm (8") chrome vanadium adjustable spanner.
- 225mm (9") hi-vis magnetic boat level. • 600mm (24") hi-vis girder section level. • 19mm x 33m black pvc insulation tape.
- 150mm euro tester range 125/250V.
- Adjustable telescopic 300mm diameter inspection mirror.
- Magnetic pick-up tool extends to 650mm.
- Bradawl.
- 450g (16oz) claw hammer wood shaft.
- 3m/10ft Senator hi-vis locking tape.
- 13 segment 9mm standard snap-off blade knife.
- Retractable trimming knife c/w 5 blades.
- Junior hacksaw frame c/w hardened blade.
- DIY hacksaw frame.
- 177mm (7") plastic handled multi-purpose household scissors. • 63mm (2½") half tang filling knife.
- 76mm (3") half tang scraper. • 150mm (6") linesman's plier. • 125mm (5") snipe nose plier.
- 125mm (5") diagonal cutting nipper.
- 255mm (10") straight jaw grip wrench.
- 22" x 8pts homesaw hand saw.



Set contents may vary slightly according to product development and availability.

Number of Pieces	Weight each	Order Code
61	16kg	SEN-595 -0540K

Hand Tools



SENATOR *33 Piece Home Handyman Kit*
QUALITY TOOLING

HHK32

Supplied in a robust plastic toolbox c/w double latch.

Contents*:

- Tuff-E toolbox.
- 18 piece wood, metal and masonry drill set.
- 8 piece fluted handle screwdriver set.
- 6" diagonal cutting nippers.
- 3m/10ft Locking tape rule.
- 10" Straight jaw high strength
- 6" snipe nose pliers/side cutter blade knife.
- 7" linesman pliers.
- 8 segment 18mm snap-off grip wrench.

*Set contents may vary slightly according to product development and availability.



33
PIECES

Number of Pieces	Weight each	Order Code
33		SEN-595 -0500K

Engineer's Workshop Tool Kit - 47 pieces

- 6 piece 16cm cut 2 assorted needle file set.
- 10x 12 x 1/2" x 18T all hard hacksaw blades.
- 8" (200mm) C/V adjustable spanner.
- 6" (150mm) stainless steel rule with pocket clip.
- Metric and inch feeler gauge, blade length: 60mm.
- 1lb ball pein hammer with hickory shaft.
- 16oz black rubber mallet with wooden shaft.
- 5m/16ft locking tape rule with chrome casing.
- 8 segment 18mm heavy duty snap-off blade knife.
- Retractable trimming knife.
- 12" DIY hacksaw.
- 6" heavy duty snipe nose pliers with side cutter.
- 6" diagonal cutting nipper.
- 7" linesman pliers.
- 10" multiple slip joint plier.
- 10" straight jaw high strength grip wrench.
- 8 piece fluted handle screwdriver set.
- 7 piece 6 - 19mm drop forged open-ended spanner set.
- 10" straight blade tinsnip.
- 21" 5 tray cantilever toolbox.

Set contents may vary slightly according to product development and availability.



47
PIECES

Number of Pieces	Weight each	Order Code
47	6.4kg	SEN-595 -0700K

PRODUCTS ARE ONLY AVAILABLE VIA YOUR DISTRIBUTOR

Hand Tools

GROUP 595 TOOL KITS

KENNEDY 102 Piece Service Engineer's PROFESSIONAL Tool Kit

Contents

- Hi-impact mobile tool case.
- 6 Piece 16cm cut 2 needle file set.
- 150mm chrome finish adjustable wrench.
- 150mm mains tester range 125/250V.
- 19mm x 33mm insulation tape: black, red and green/yellow pvc.
- Soldering iron 25W 240V.
- Cable stripping knife.
- Desoldering gun.
- 17g 1.0mm diameter 60/40 cored solder.
- Square head centre punch 3.2mm x 100mm.
- 150mm/6" flexible rustless rule.
- Precision tweezers: 115mm sharp nose, 120mm flat blade.
- Eye loupe.
- 30mm dia. telescopic inspection mirror (handle expands to 480mm).
- 225g (1/2lb) ball pein hammer.
- 7.5m/25' steel tape.
- 13 segment blade mini autolock retractable knife.
- Junior hacksaw frame c/w hardened blade.
- 10 Junior hacksaw blades for metal.
- 215mm plastic handle scissors.
- Magnetic pick up tool.
- 160mm snipe nose plier.
- 160mm diagonal cutting nipper.
- 160mm combination plier with side cutter.
- 150mm insulation and wire stripping plier.
- 115mm precision flat nose pliers.
- 115mm precision long nose pliers.
- 115mm precision nippers.
- 115mm precision end cutting nippers.
- Pro-Torq grip screwdrivers with chrome vanadium blade: slotted 100mm x 6mm; crosspoint 76mm x No.0 and No.1, 6mm x No.2; supadriv 76mm x No.0 and 1, 100mm x No.2; electricians: parallel 150 and 200 x 5mm.
- Offset screwdrivers: 5mm x No.1 and 6mm x No. 2.
- 1000V VDU insulated screwdrivers: parallel 4 x 100mm; slotted 5.5 x 125mm.
- Torx screwdrivers: T6, T8 and T10.

- 11 piece screwdriver and tool set: parallel 1, 1.2, 1.4, 1.8, 2.4 and 3mm; crosspoint PHO-2, PHO and PH1, fine point awl and tweezers.
- 7 piece electronic screwdriver set: parallel 1.4, 2, 2.4 and 3mm; crosspoint PHO-3, PHO-2 and PHO.
- 6 piece chrome vanadium steel 0 - 11 BA open ended spanner set.
- 20mm diameter sash tool.
- 9 piece hex key set 1.5 - 10mm.
- Chrome vanadium combination spanners: 5.5, 6, 7, 8, 9 and 10mm.

Set contents may vary slightly according to product development and availability.

**102
PIECES**



Number of Pieces	Weight each	Order Code
102	13.0kg	KEN-595 -3020K

56 Piece Standard Service Tool Kit

Suitable for use by service engineers, electricians and tradesmen. All Kennedy industrial quality tools carry a quality guarantee.

Contents:

- 430 x 340 x 160mm abs plastic, aluminium reinforced, tool case.
- 150mm chrome adjustable wrench.
- 19mm x 33mm black pvc insulation tape.
- 150mm mains tester range 125/250V.
- Soldering iron 25W/240V.
- Desoldering gun.
- 17g 1.0mm diameter 60/40 cored solder.
- 115mm sharp nose precision tweezers.
- 30mm diameter inspection mirror (handle extends up to 480mm).
- 7.5m/25ft steel tape.
- 13 segment-blade mini autolock retract knife.
- Junior hacksaw frame and blade.
- Magnetic pick up tool (extends to 550mm).
- 160mm snipe nose plier.
- 160mm diagonal cutting nipper.
- 160mm engineer's combination plier with side cutter.
- 150mm insulation and wire stripping plier.
- 115mm precision nippers.

- 115mm precision end cutting nippers.
- Chrome vanadium blade screwdrivers: crosspoint No.0, 1 and 2pt; slotted 6mm; supadriv No.0, 1 and 2pt.
- Offset screwdrivers: 5mm slot x No.1pt, 6mm slot x No.2pt.
- Insulated screwdrivers: parallel 4 x 100mm 1000V VDU, slotted 2.5 x 85mm.
- 20mm sash tool.
- 11 piece screwdriver and tool set: parallel 1, 1.2, 1.4, 1.8, 2.4 and 3mm; crosspoint PHO-2, PHO and PH1; fine point awl and tweezers.
- 9 piece hex key set 1.5 - 10mm.
- Chrome vanadium combination spanners: 5.5, 6, 7, 8, 9 and 10mm.

Set contents may vary slightly according to product development and availability.

**56
PIECES**



Number of Pieces	Weight each	Order Code
56	6.8kg	KEN-595 -3000K

Hand Tools



122 Piece 'Deluxe' Service Engineers Tool Kit

This superb kit contains all the necessary tools for the Service Engineer in a Sturdy Aluminium Case partitioned to keep tools organised and readily accessible.



Contents

- Aluminium tool case.
- 6 piece 16cm needle file set.
- 150mm adjustable wrench.
- Digital multimeter.
- 25/250V mains tester.
- 19mm x 33m insulation tape: black, red and green/yellow pvc.
- 25W soldering iron.
- Cable stripping knife.
- Desoldering gun.
- 60/40 cored solder.
- Butane soldering torch.
- Centre punch 2.4mm x 3.2mm.
- 2x parallel pin punches.
- 150mm/6" flexible rustless rule.
- Machinists scriber.
- Sharp nose tweezers.
- Flat blade tweezers.
- Eye loupe.
- Telescopic inspection mirror.
- Magnetic pick up tool (extends to 550mm).
- 225g (1/2lb) ball pein hammer.
- 3 1/2oz cross pein hammer.
- Scissors.
- 7.5m/25ft steel tape.
- Retractable knife.
- Auto return utility knife.
- Junior hacksaw and blade.
- 10 junior hacksaw blades.
- 150mm flat nose plier.
- 150mm insulation and wire stripping plier.
- 150mm wire crimper/stripper.
- 160mm snipe nose plier.
- 160mm diagonal cutting nipper.
- 160mm combination plier.
- 4 piece circlip plier set.
- 177mm locking plier.
- 115mm precision flat nose plier.
- 115mm precision long nose plier.
- 115mm precision nippers.
- 115mm precision end cutting pliers.
- 165mm soft touch pliers.
- Pro-Torq grip screwdrivers with chrome vanadium blade: slotted 100mm x 6mm; crosspoint 76mm x No.0 and No.1, 6mm x No.2; supadriv 76mm x No.0 and 1, 4" x No.2; electricians: parallel 150 and 200 x 5mm.
- Offset screwdrivers: 5mm x No.1, 6mm x No. 2.
- Insulated screwdrivers: parallel 4 x 100mm, 1000V VDU, slotted 5.5 x 125mm.
- Torx screwdrivers: T6, T8 and T10.
- Aluminium pocket torch.
- 11 piece screwdriver and tool set.
- 7 piece electronic screwdriver set.
- 6 piece 0 - 11 BA open ended spanner set.
- 9 piece 5.5 - 13mm combination spanner set.
- Multi-purpose snips.
- 7 piece metric hexagon key set.
- Multi-purpose oil.
- 20mm sash tool.
- 100 cable ties.

Set contents may vary slightly according to product development and availability.

Number of Pieces	Weight each	Order Code
122	14.0kg	KEN-595 -3040K

PRODUCTS ARE ONLY AVAILABLE VIA YOUR DISTRIBUTOR

GROUP 595 TOOL KITS

KENNEDY Electricians VDE Tool Bag & Kit - 16 Piece

Heavy-duty tear resistant tool bag with velcro fastening flap. Double webbed shoulder strap fixed with metal release clasps. Two removable tool boards inside which have a unique tool storage securing system built in. All tools are VDE approved.

Contents:

Electrician's tool bag (320 x 340 x 125mm). 150mm euro tester will detect 'live' electricity supply. Suitable for AC to 125 -250 volts. 3mm wide tip. Conform to VDE 0630 Part 4. 145mm (5³/₄") Pro-Torq grip diagonal nipper 1000V insulated. 160mm (6³/₈") Pro-Torq snipe nose plier 1000V insulated. 165mm (6¹/₂") Pro-Torq engineer's combination plier 1000V insulated. 170mm (6³/₄") Pro-Torq wire stripper 1000V insulated. 7-pce VDE dual grip screwdriver set: No.0 x 60, No.1 x 80 and No.2 x 100mm, 2.5 x 75, 4.0 x 100, 5.5 x 125 and 6.5 x 150mm. 180mm (7") insulated cable knife, curved blade. 2x small parts storage boxes.



Width (mm)	Depth (mm)	Height (mm)	Weight each	Order Code
320	125	340		KEN-595 -3400K

'Live Line' VDE Tool Kit - 17 Piece

Contents:

Tear resistant tool roll (600 x 300mm). 190mm euro tester - will detect 'live' electricity supply. Suitable for AC to 125 -250 volts. 3mm wide tip. Conform to **VDE 0630 Part 4**. 145mm (6¹/₄") Pro-Torq grip diagonal nipper 1000V insulated. 160mm (6³/₈") wire stripper, engineer's combination plier and snipe nose plier 1000V insulated. 240mm (9¹/₂") Water pump box joint pliers 1000V insulated. 200mm adjustable wrench 1000V insulated. 7-pce insulated VDE screwdriver set: Contents: Parallel: 2.5 x 85mm, 4.0 x 100mm, 5.5 x 125mm, 6.5 x 150mm. Crosspoint: No. 0 x 75mm, No. 1 x 100mm, No. 2 x 200mm. 180mm (7") insulated cable knife curved blade. 210mm (8¹/₄") Cable cutter.



Both Rolls have a riveted carry handle on the outside.

Width (mm)	Depth (mm)	Height (mm)	Weight each	Order Code
320	125	340		KEN-595 -3420K

KENNEDY 1000V Dual Grip Professional Screwdriver & Plier Set

10 Piece Set

Fully insulated professional high grip dual material handles that are VDE tested up to 1000V. Screwdrivers have magnetic tips, chrome vanadium steel blades and a hanging hole in handle. Pliers have chrome vanadium steel double polished head and joint heads and are suitable for production line environments.

Contents: Screwdrivers: Crosspoint No.0 x 60mm, No.1 x 80mm, No.2 x 100mm. Parallel 2.5 x 75mm, 4.0 x 100mm, 5.5 x 125mm, 6.5 x 150mm.

Pliers: 6³/₈" Pro-Torq snipe nose pliers, 6¹/₄" Pro-Torq grip nipper pliers, 6¹/₂" Pro-Torq engineering combination pliers.



Number of Pieces	Weight each	Order Code
10		KEN-595 -1600K

Pro-Torq Maintenance Tool Bag & Kit - 29 Piece

Contents:

Electrician's tool bag (320 x 340 x 125mm). 2x small bits organiser cases. 1 tool board unique system to secure tools whilst in transit. 140mm (5¹/₂") autoloader and lock knife - 13 segment snap-off blade. 165mm (6¹/₂") Pro-Torq diagonal nippers. 150mm (6") Pro-Torq snipe nose pliers with side cutter. 150mm (6") Pro-Torq combination pliers. 6-pce Pro-Torq screwdriver set: Crosspoint: No.1 x 75, No.2 x 100. Flared: 6.3 x 100, 8.0 x 200. Parallel: 5.0 x 75, 5.0 x 150mm. 7-pce Pro-Torq precision screwdriver set: Parallel tips: 1.4, 2.0, 2.4 and 3.0mm. Crosspoint tips: PH0-3, PH0-2 and PH-0. 200mm (8") soft grip phosphate adjustable wrench. 8-pce Pro-Torq hex wrench set on clip 1.5 - 8.0mm.

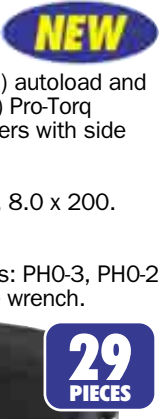

Width (mm)	Depth (mm)	Height (mm)	Weight each	Order Code
320	125	340		KEN-595 -3440K

Pro-Torq Maintenance Tool Roll Kit - 45 Piece

Contents:

Tear resistant tool roll (600 x 300mm). 140mm auto load and lock knife - 13 segment snap-off blade. Telescopic magnetic pick-up tool extends to 550mm (22"). 150mm (6") Pro-Torq snipe nose pliers with side cutter. 165mm (6¹/₂") Pro-Torq diagonal nippers. 6-pce Pro-Torq screwdriver set: Crosspoint: No.1 x 75, No.2 x 100. Flared: 6.3 x 100, 8.0 x 200. Parallel: 5.0 x 75, 5.0 x 150mm. 14 piece chrome vanadium combination spanner set 6-19mm. 3-pce offset screwdriver set: No.1 Crosspoint x 3/16" Parallel, No.2 Crosspoint x 1/4" Parallel & No.3 Crosspoint x 5/16" Parallel. 7-pce Pro-Torq precision screwdriver set: Parallel tips: 1.4, 2.0, 2.4 and 3.0mm. Crosspoint tips: PH0-3, PH0-2 PH-0. 200mm (8") soft grip phosphate adjustable wrench. 8-pce Pro-Torq hex wrench set on clip 1.5-8.0mm.

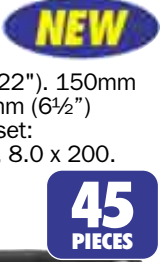

Width (mm)	Height (mm)	Weight each	Order Code
330	600		KEN-595 -3460K

7 Piece Maintenance Tool Kit

MTK7

For everyday use. Supplied in PVC tool roll.

Contents:

- Chrome adjustable wrench.
- Slotted electricians VDE screwdriver.
- Slip joint pliers.
- High tensile diagonal cutting nippers.
- Universal combination pliers.
- No.2 Crosspoint engineer's screwdriver.
- Flared slotted engineer's screwdriver.

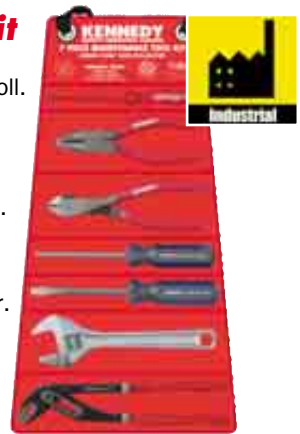

Number of Pieces	Weight each	Order Code
7	1.3kg	KEN-595 -0070K

Hand Tools

SENATOR CYCLONE *Cycle Work Stand*

CWS152

Quick to set up, this fold-away cycle work stand has telescopic height adjustment, and plastic jaw clamps to securely grip the frame or seat post.

Specifications:

Construction: light alloy and tough ABS plastic. Rubber feet.
 Dimensions: closed: 23 x 22 x 102cm,
 open: 70 x 100 x 164cm.
 Jaw opening: min: 25mm dia. max: 75mm dia.
 Weight: 5.3kg.



Cycle not included

Description	Order Code
Cycle Work Stand	SEN-595 -4480K

Cycle Repair Kit 15 Piece

This comprehensive kit is ideal for cycle repairs at home, comes in its own wallet and measures 90 x 200 x 40mm. Large than the multi tools but still small enough to carry in a ruck sack or pannier for those touring holidays.

Contents:

- 2 x 'Y' box wrenches - 8, 9, 10mm and 12, 13, 14mm.
- 150mm (6") adjustable wrench 20mm max. opening.
- Hook spanner with 15 and 16mm open ended cone wrench.
- Screwdriver handle with:
- Crosspoint - No.1 and No.2.
- Slotted bits - 4 and 6mm.
- 3x hex key wrenches - 4, 5, 6 and 8mm hex adaptor.
- 1x forged steel 'O' spoke adjuster - 10, 11, 12, 13, 14 and 15G.E.
- 3x tyre levers.

15
PIECES



Description	Order Code
15 Piece Cycle Repair Kit	SEN-595 -4460K

SENATOR CYCLONE

NEW



These specialist products are made from quality materials to give high levels of performance and durability. Whether you are doing emergency roadside repairs or general maintenance, the **SENATOR CYCLONE** range is all that you would expect from a top supplier of industrial tools.

Cycle Multi Tools

CMT091 - One of the smallest multi tools on the market. Comfortable in the hand, or in the pocket. It has chrome vanadium steel blades and a matt coated frame.

Includes:

- Hex keys, 2, 2.5, 3, 4, 5 and 6mm.
- Torx key T25.
- No.1 crosspoint bit.
- 5mm slotted bit.

9 in 1



Description	Order Code
CMT091 - 9 in 1 Multi Tool	SEN-595 -4420K

CMT161 - Another very compact multi tool from **SENATOR CYCLONE** range with 16 useful chrome vanadium blades and chain rivet extractor.

Includes:

- Hex keys, 2, 2.5, 3, 4, 5, 6mm.
- Adaptor for 8mm hex key.
- 1x 10mm spanner.
- 1.2mm and No.1 crosspoint bits.
- 1.2mm and 5mm slotted bits.
- 1x tyre lever.
- 2x spoke wrenches - 14 and 15G.E.
- 1x chain rivet extractor.

NEW

16 in 1



Description	Order Code
CMT161 - 16 in 1 Multi Tool	SEN-595 -4400K

CMT221 - A superb multi tool for almost every cycling emergency. Robust construction with chrome vanadium steel blades mounted in two attractive plastic and cast steel frames held together with a magnet. Complete with its own rubber pouch.



Includes:

- Integral cast steel chain rivet extractor with patented hands free folding chain retainer and pin compartment.
- Hex keys - 2, 2.5, 3, 4, 5, 6 and 8mm.
- Ring spanners - 8, 9, 10, 13, 14, and 15mm.
- Spoke wrenches - 3.22, 3.33, 3.45, and 3.96mm.
- No.2 crosspoint bit.
- T25 torx bit and storage pouch.

22 in 1

Description	Order Code
CMT221 - 22 in 1 Multi Tool	SEN-595 -4440K

GROUP 597 WOODWORKING TOOLS

SENATOR *Carpenters*
QUALITY TOOLING *Chisel Set*

Made from quality materials and complete with its own canvas storage wallet.
Bevel edged chrome vanadium blades, hardened, tempered, ground and polished. Comfortable bi-material handles with impact resistant end caps.

4
PIECES

Set Contents:
6mm (1/4"), 13mm (1/2"), 19mm (3/4") and 25mm (1") chisels.

No of Pieces	Order Code
4	SEN-597 -2970K



Wood Carving Tool Set



Contents: four straight gouges, two square chisels, two skew chisels, two V-parting tools, one veiner and one spoon bit. Alloy steel blades. All supplied in a quality wooden presentation case. Blade length: 110mm, handle length: 95mm.

12
PIECES



Number of pieces	Weight each	Order Code
12	1.30kg	SEN-597 -3960K

KENNEDY *Bevel Edge*
QUALITY INDUSTRIAL TOOLING *Wood Chisels*

For Sharpening Stones

See
Group
255



Designed to give a life-time of high performance. Chrome vanadium alloy blades, hardened, tempered, ground and polished. 'CAB' (Cellulose Acetate Butyrate handles).

Craftsman: Hammer-blow resistant handles. For craftsmen and joiners.



Blade mm	Width Inch	Weight per 12	Order Code
6	1/4"	1.90kg	KEN-597 -2800K
10	3/8"	2.20kg	-2820K
13	1/2"	2.35kg	-2840K
16	5/8"	2.50kg	-2860K
19	3/4"	2.60kg	-2880K
25	1"	3.00kg	-2900K
38	1 1/2"	3.85kg	-2940K



Set No. of Pieces	Contents	Weight each	Order Code
4	6, 13, 19, & 25mm	880g	KEN-597 -2980K

Professional
'Classic' pattern. For professional carpenters.

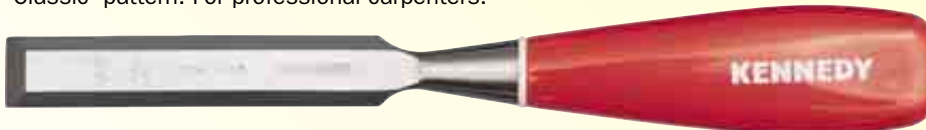

Blade mm	Width Inch	Weight per 12	Order Code
6	1/4"	1.90kg	KEN-597 -2160K
10	3/8"	2.10kg	-2240K
13	1/2"	2.20kg	-2320K
19	3/4"	2.50kg	-2480K
25	1"	2.80kg	-2640K
38	1 1/2"	3.70kg	-2680K



Set No. of Pieces	Contents	Weight each	Order Code
4	6, 13, 19, & 25mm	800g	KEN-597 -2970K



Wood Turning Tool Set

Contents: three straight gouges, two skew chisels, one V-parting tool, one round nose and one diamond point. HSS blades in a quality wooden presentation case. Blade length: 125mm, handle length: 250mm.

8
PIECES



Number of pieces	Weight each	Order Code
8	2.25kg	SEN-597 -3940K

KENNEDY *Beechwood*
QUALITY INDUSTRIAL TOOLING *Mallet*

Traditional carpenter's pattern. Weight: 520g.

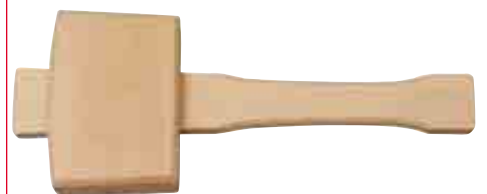

Head Size	Weight each	Order Code
114mm (4 1/2")	520g	KEN-597 -6450K

Hand Tools



KENNEDY *Breast Drill*
QUALITY INDUSTRIAL TOOLING

Heavy duty two speed breast drill with a heavy cast construction and enclosed gearing. Fitted with a three jaw keyless 10mm chuck and supplied with two removable wooden handles. The plate is pressed against the chest to force the drill point into the work.

2 SPEED

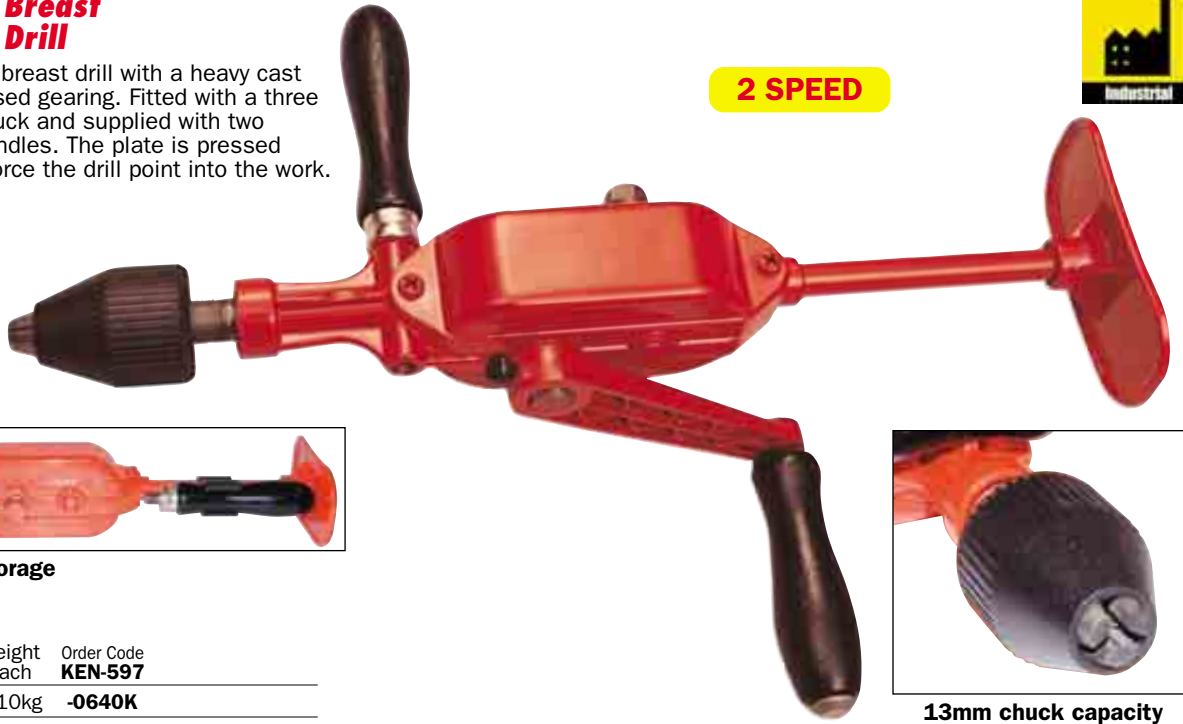

Packs flat for easy storage

Chuck Capacity	Overall Length	Weight each	Order Code
13mm	330mm	1.10kg	-0640K



13mm chuck capacity

Hand Drill

Double pinion drill with die cast body and three jaw keyless chuck. Plastic handle with plastic grips and screw top, for bit storage. Used for small drilling operations.



8mm chuck capacity



Extra Grip



Double Pinion

Overall Length	Weight per 6	Order Code
215mm	2.80kg	-0600K

Tacklifter

Beechwood handle, V-cut.



Length	Weight each	Order Code
195mm	100g	-7150K

Bradawl

For starting screw holes etc. Plastic handle.



Length x Diameter	Weight each	Order Code
38 x 3mm	55g	-7230K

Beechwood Handled Gimlet

Self starting screw point. Designed for producing holes without the risk of splitting surface. With spiral fluted shank. Beechwood handle.

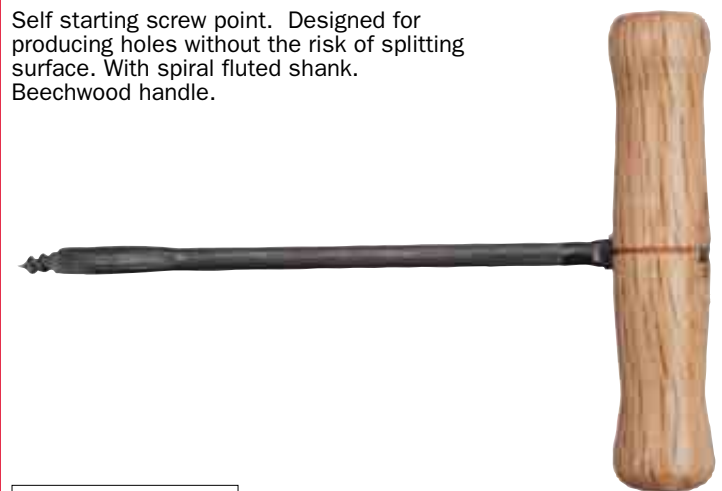

Length x Diameter	Weight each	Order Code
65 x 3mm	45g	-7280K

PRODUCTS ARE ONLY AVAILABLE VIA YOUR DISTRIBUTOR

GROUP 597 WOODWORKING TOOLS

KENNEDY Marking & Mortice Gauges
QUALITY INDUSTRIAL TOOLING

Beechwood Marking Gauge

For marking wood and laminate parallel to edge, prior to cutting, sawing or chiselling. With plastic thumbscrew. Capacity: 0 - 150 (6").



Gauge Type	Weight per 12	Order Code
Marking	1.7kg	-6600K

Rosewood Mortice Gauge

Manufactured from rosewood. Craftsman quality with pull slide, brass adjustment screw and brass plated head which is wear resistant and improves accuracy. Fitted with a single and a double spur for marking out mortices.



Capacity: 0 - 150mm (6").

Gauge Type	Weight per 12	Order Code
Mortice	1.7kg	-6650K

Sliding Bevels

Used for marking regular and irregular angles. The 9" sliding steel blade can be locked into any position using the brass thumbscrew. Rosewood stock with brass tips for greater wear resistance.



Head Size	Weight Per 12	Order Code
190mm (7½")	1.95kg	-6750K
230mm (9")	2.20kg	-6790K

Try Squares

Used for marking out right angles and testing squareness. Rosewood stock with brass face for greater wear resistance. Blades are manufactured from hardened steel, and secured by steel washers with brass rivets. Solid rosewood stock with solid brass facing securely fixed to the stock provides a hard wearing contact edge.



Head Size	Weight Per 12	Order Code
150mm (6")	2.90kg	-6860K
230mm (9")	3.80kg	-6890K

Rafter's Square

Manufactured from hardened and tempered ground steel. Graduated to 2mm on one side and 1/8" and 1/16" increments on the other. In hands of a skilled carpenter the simple rafter's square becomes an indispensable calculating device of immense capacity. Enabling the carpenter to easily determine the length of any common, hip, valley or jack rafter for any pitch of roof. To make the proper cuts, top and bottom as well as slide or cheek cuts for any rafter.



Body Length	Tongue (mm)	Weight per 12	Order Code
610mm	406	11.1kg	-6950K

Heavy Duty Chalk Lines

Aluminium Alloy Case
With foldaway locking handle. Heavy duty robust design, complete with universal hook.



Chalk not included

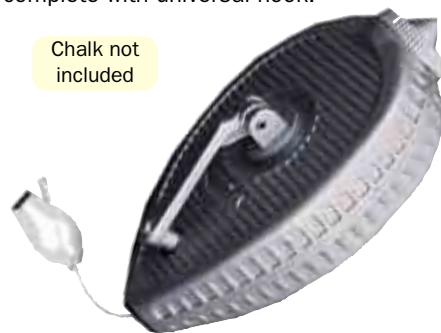

Line Length	Weight per 12	Order Code
30 Metres	2.90kg	-7300K

Die Cast Zinc Alloy Case

With a red satin finish. Complete with folding locking handle. Felt gasket distributes uniform chalk coating onto line. With sliding hatch for filling. Universal hook attaches to any projection or slot.

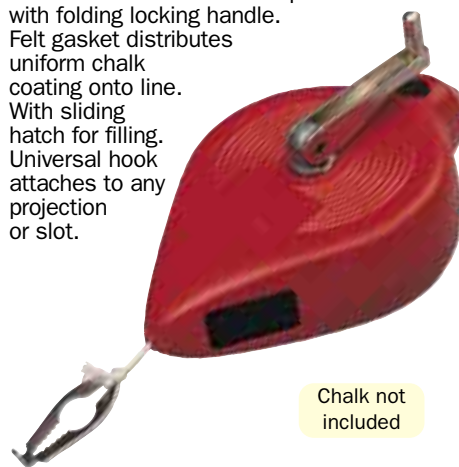

Chalk not included

Line Length	Weight per 6	Order Code
30 Metres	2.30kg	-7320K

Chalk Line Refills - Large

Suitable for all chalk lines. Good colour fastness and weather resistance. Supplied in squeezable bottle.

Available in three colours:

Blue for general use externally and internally.
Red for exterior masonry work indelible in use.
White for interior use such as fixing a dado rail.



250gm NOW AVAILABLE

Colour	Weight each	Order Code
Blue	135g	-7330K
Red	135g	-7340K
White	135g	-7350K
Blue	250g	-7370K
Red	250g	-7380K
White	250g	-7390K

Hand Tools



KENNEDY *Angle Finder - Magnetic Base*
QUALITY INDUSTRIAL TOOLING

Can be used independently as a 'quick check' tool or to convert a rule or square into a precision angle finder. High strength built-in ceramic magnet with vee groove for use on bars and pipes. Accuracy ± 0.5%. For the most accurate readings it is recommended that the angle finder is attached to a steel rule or square by means of the magnet or screws.



High strength built-in ceramic magnet with vee groove for use on bars and pipes.



Dial Reading	Weight each	Order Code
0-90° (Any Quadrant)	45g	-7500K

Combination Squares

Multi-functional. Can be used as try square, mitre square, depth gauge, spirit level, marking gauge and rule. Supplied with scribing tool. Diecast aluminium alloy head with the 6" rule and diecast zinc alloy head with the 12" rule. Precision rolled blades.

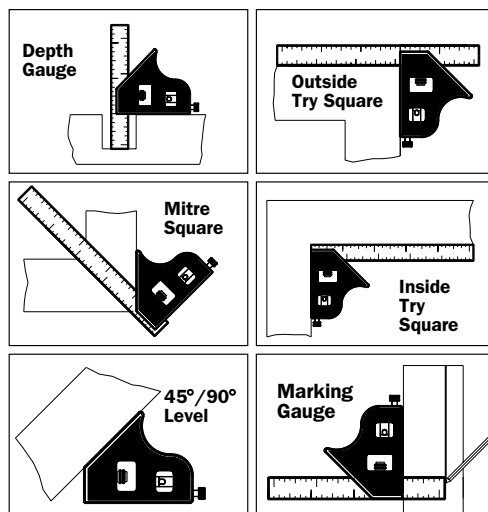

Supplied with scribing tool.

Blade Length	Weight Per 5	Order Code
150mm/6"	2.80kg	-7060K
300mm/12"	2.80kg	-7120K
Spare Lock Nut & Mandrel for 12"		-7132K
Spare Scriber for 6"		-7134K
Spare Scriber for 12"		-7136K

Beechwood Folding Rules Class III

Manufactured from Beechwood for strength and flexibility and painted bright yellow. Metric and inch graduations, large, clear and deep for increased tool life and easy reading. Sizes available: 1m x 5 folds: 2m x 10 folds. Graduations: Metric - mm & cm (cm figures in red) Inch - 1/16", 1/8", 1/4", 1/2", 1" Accuracy: Class III



Size	Order Code	
1m x 5 folds	-3980K	N/A
2m x 10 folds	-3990K	N/A

SENATOR *Aluminium Cutting & Measuring Edge*
QUALITY TOOLING

Lightweight hardened and anodised aluminium with central handle. Marked with mm, cm, inches and 1/8" with useful conversions.

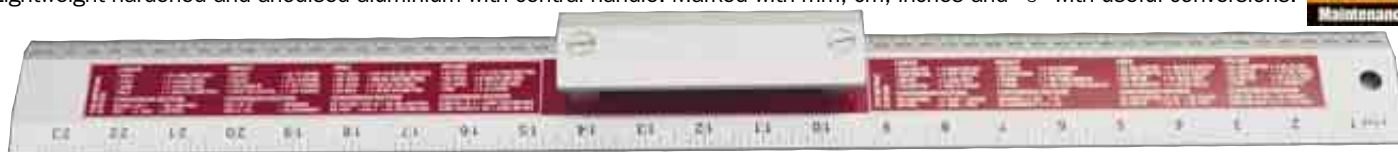

Length	Width	Weight each	Order Code
1000mm	58mm	0.80kg	-7040K



PRODUCTS ARE ONLY AVAILABLE VIA YOUR DISTRIBUTOR

Using Your Plane

- Always hold the plane firmly to ensure optimum balance and control. Ensure the workpiece is secure and stand behind the plane - never pull a plane towards your body.
- When planing end-grain, plywood, blockboard or difficult/curlly grain, the direction of the cut is extremely important. A 'slice' action is advised or splitting may occur. This is achieved this by holding the plane at an angle as shown.
- Splitting can generally be prevented in several ways:
 - 1) By planing towards the center of the workpiece
 - 2) Bevel the corner of the workpiece before planing
 - 3) Clamp scrap wood level with the edge of the surface being planed and plane it straight across.



Maintaining Your Plane

- A plane is a precision tool, therefore it should always be treated with care. Always store the plane on its side — this will avoid unnecessary damage to the blade.
- Always sharpen the blade before use. This will make it easier, and safer to use and produce a superior surface finish.
- Before sharpening the blade take the blade out of the plane and remove the cap iron. Always lay the blade flat on a firm surface before taking out the screw.
- Sharpen your blade using an oilstone. Best results are achieved by using a honing guide - this will give the ideal angle at the cutting edge of the blade.
- Use machine oil to keep the surface of the stone wet but remove excess before use. This is to prevent dust and metal particals from clogging the stone.
- Remove any burrs by laying the front of the blade flat on the oilstone and work it in a "figure-eight" motion.
- Painted surfaces should be sanded or stripped back before planing in order to avoid clogging of the blade and damage to the timber.
- Never plane over nails, this will damage the blade.
- Always wipe the blade with a cloth before replacing it.
- Candle wax applied to the sole of the plane may reduce friction, especially on freshly cut timber.

SENATOR[®] No. 200 Block Plane
QUALITY TOOLING

Suitable for any single handed operation in particular for end-grain work. The low angle plane cutter ensures minimal vibration giving an excellent finish on many man made materials such as plastic laminates. Adjustable 40mm width steel cutting blade with ground base and sides for smooth planing. Large screw for accurate adjustments.



Cast iron body with adjustable cutter depth and alignment.

Model Number	Length (mm)	Iron Width	Weight each	Order Code
200	178	41mm	0.80kg	SEN-597

No. 4 Smoothing Plane

Used for general purpose smoothing and final finishing. Featuring a robust level cap designed to lock down on three points for secure location of the cutting iron. High performance carbon steel blade. hardened and tempered to retain a keen cutting edge to cut even the hardest of woods. Impact resistant ABS resin handle and knob are extremely robust and contoured to fit comfortably in the hand, for maximum control and reduced user fatigue. Suitable for single and two handed operations. Traditional adjusting nut for fine seating.



Model Number	Length (mm)	Iron Width	Weight each	Order Code
4	247	51mm	1.93kg	SEN-597

No. 5 Jack Plane

Fully adjustable metal plane for stock removal and truing up long edges or levelling wide boards. Kidney shaped lever cap screw hole prevents accidental slippage of cutter. High performance carbon steel blade. hardened and tempered to retain a keen cutting edge. Fully adjustable frog for all tasks and timber types. Virtually unbreakable polypropylene handle and knob shaped for comfort. Finger tip adjustment for depth of cut and cutter alignment. Tight fitting spring steel cap iron for optimum shaving flow. Cast fine grey iron base for stability and wear resistance. Precision ground base and sides ensure performance to the highest tolerances.



Model Number	Length (mm)	Iron Width	Weight each	Order Code
5	355	51mm	3.2kg	SEN-597

Hand Tools

KENNEDY *Surface Forming Tools*
QUALITY INDUSTRIAL TOOLING

With tough enamelled alloy bodies and high carbon heat treated steel blades.

Flat File - Straight Handle

For straight filing with flat blade as standard. Plastic handle.
 Blade length: 255mm.
 Blade width: 40mm.
 Overall length: 395mm.



Plane

For conventional plane type filing. With flat blade as standard.
 Black plastic handle. Blade length: 255mm.
 Blade width: 40mm. Overall length: 285mm.



Block Plane

For single handed use, giving compactness and precision filing.
 Blade length: 140mm.
 Blade width: 40mm.
 Overall length: 140mm.



Shaver Tool

With plastic holder.
 Blade length: 63mm.
 Blade width: 40mm.
 Overall length: 185mm.



Round File - Straight

For convex and concave surface shaping. Wooden handle.
 Blade length: 255mm. Blade width: 16mm. Overall length: 360mm.



Tool Style	Blade Length	Blade Width	Overall Length	Weight each	Order Code
Flat File	255mm	40mm	395mm	400g	-1010K
Plane	255mm	40mm	285mm	400g	-1070K
Block Plane	140mm	40mm	140mm	130g	-1110K
Shaver Tool	63mm	40mm	185mm	60g	-1150K
Round File	255mm	16mm	360mm	125g	-1240K

Replacement Blades

To Suit	Blade Type	Weight each	Order Code
Flat File or Plane	Flat	40g	-2020K
	Half-Round	40g	-2040K
Block Plane	Flat	30g	-2060K
Shaver Tool	Curved	10g	-2080K
Round File	Round	40g	-2100K

4 Piece Surface Forming Set



No. of Pieces	Contents	Weight each	Order Code
4	As above	840g	-1540K

Cabinet Scraper Set

For fine surface finishing of intricate contour surfaces. Used to manually remove small amounts of material and excels in tricky grain areas where hand planes would cause tear out. They will stand up to any heavy duty scraping task with minimum tear out. For best results, these scrapers should be burnished to a razor sharp edge.

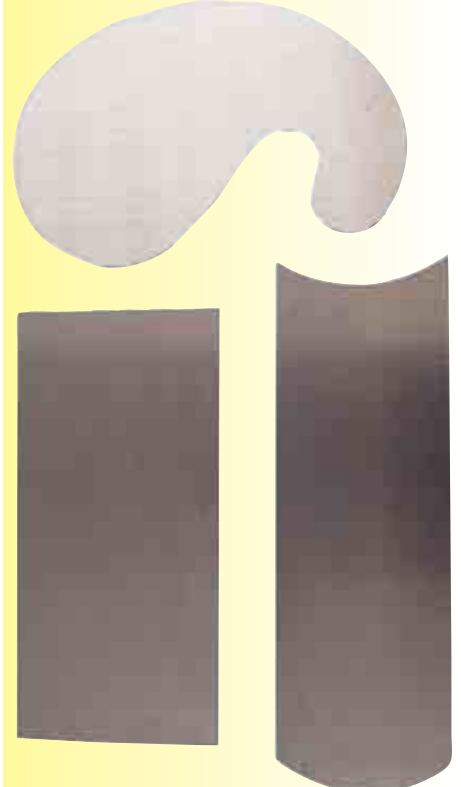

No. of Pieces	Weight Set	Order Code
3	170g	-7400K

SITESAFE Hardpoint Hand Saw

Hardened and tempered blade. Designed to cut chipboard, blockboard, timber, plywood, hardboard, plasterboard and laminates. Specially hardened teeth to stay sharp longer. Tough handle with fingerline for comfort and accuracy. 8 points per inch.

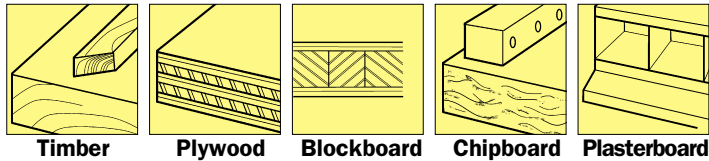

NEW

Description	Order Code
560mm (22") Hardpoint Hand Saw	SSF-597-4780K

KENNEDY Meteor Hand Saw

550mm (22") hand saw with a high quality hardened and tempered steel blade with specially hardened teeth. Stays sharp longer. Fitted with a bi-material handle with fingerline for comfort and accuracy. Three ground edges per tooth. Cuts on back stroke. Designed to cut chipboard, blockboard, timber, plywood, hardboard, plasterboard, PVC and laminates.

8 points per inch (7tpi)

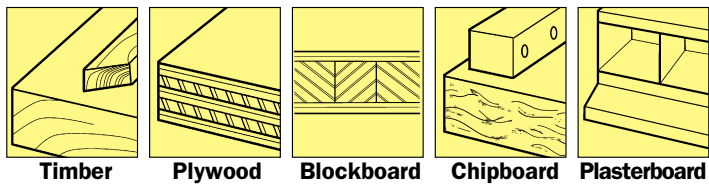

NEW



Teeth Per Inch	Weight each	Order Code
7	540g	-4900K
11	540g	-4920K

Professional Hand Saw

Superior quality skew back. Hardened and ground steel with glazed and polished blade, tensioned and fully sprung. Teeth are set and sharpened. Polished handle with brass screws. Supplied in wallet with tooth guard.

10 points per inch.

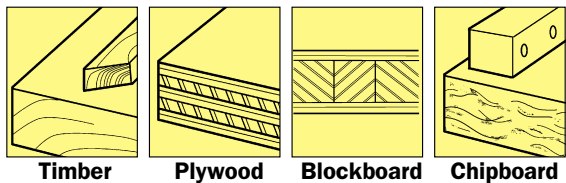

Blade Length	Weight per 10	Order Code
560mm (22")	6.7kg	-4700K

Masonry Saws

Hardened and tempered steel blade with carbide teeth. **Medium Duty** Suitable for cement based building blocks, 17 tungsten carbide tips on alternate teeth.

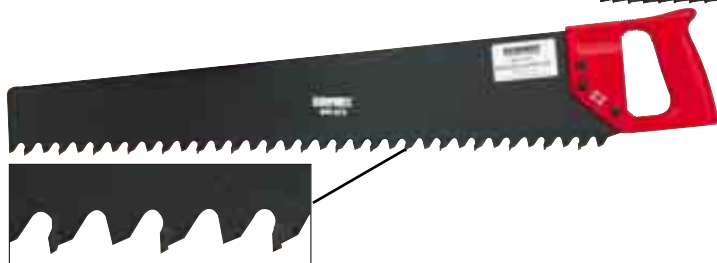

Heavy Duty Suitable for cutting man made building blocks and bricks with 35 tungsten carbide teeth.

Type	Blade Length	Weight each	Order Code
Med duty (17tpi)	622mm	1.10kg	-5720K
Heavy duty (35tpi)	490mm	1.20kg	-5740K



Hand Tools

KENNEDY *Hardpoint Tenon Saw*
QUALITY INDUSTRIAL TOOLING

Has file sharpened teeth with plain hardened cutting edges. Impact resistant handle. High quality. 13 points per inch.



Blade Length	Weight per 10	Order Code
250mm (10")	3.8kg	KEN-597
-4620K		

SITESAFE *Hardpoint Veneer Saw*
QUALITY INDUSTRIAL TOOLING

Fine cutting for veneers, plastics and sheet materials. Curved end allows cutting up to skirts and corners. Set and sharpened teeth. High impact moulded plastic handle. Hardened and tempered spring steel blade. 15 points per inch (14tpi).



Blade Length	Order Code
330mm (13")	SSF-597
-5620K	

KENNEDY *8" Brass Back Dovetail Saw*
QUALITY INDUSTRIAL TOOLING

Alloy steel blade, tensioned with hardened and ground teeth. Heavy rigid brass back and polished rosewood handle. Securely fastened with two brass screws. 20tpi.

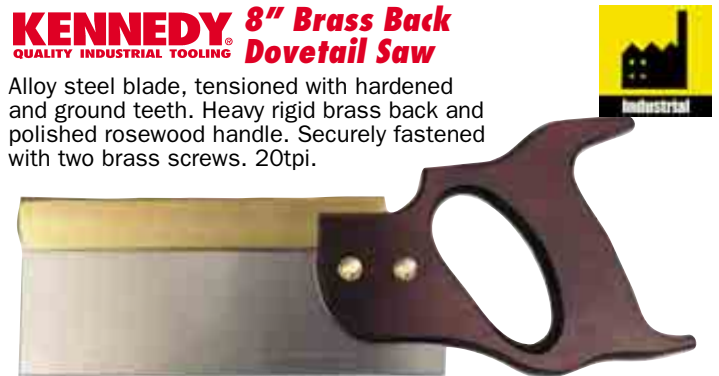

Blade Length	Weight each	Order Code
200mm (8")	500g	KEN-597
-5420K		

Hardpoint Compass Saw

Flexible spring blade. Set and sharpened teeth. High impact moulded plastic handle.

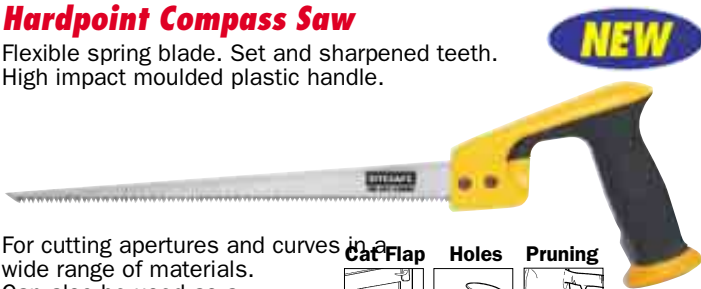

For cutting apertures and curves in a wide range of materials. Can also be used as a pruning saw.

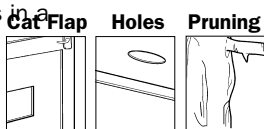

8 points per inch (7tpi)

Blade Length	Weight each	Order Code
300mm		SSF-597
-5340K		

KENNEDY *Professional Tenon Saw*
PROFESSIONAL

Manufactured from hardened and ground steel with glazed and polished blade, tensioned and fully sprung. Highly polished brass back and handle. Supplied in wallet with tooth guard. 15 points per inch.



Blade Length	Weight per 10	Order Code
250mm (10")	6.0kg	KEN-597
-4600K		

KENNEDY *Pad Saw*
QUALITY INDUSTRIAL TOOLING

For use in confined spaces.



Length	Weight each	Order Code
230mm	140g	KEN-597
Spare Coarse Blade to Suit Above		-5280K

Plasterboard Saw

Suitable for rapidly cutting holes in plasterboard. Hardened and tempered carbon steel blade with polished rosewood handle and brass ferrule. 7tpi.

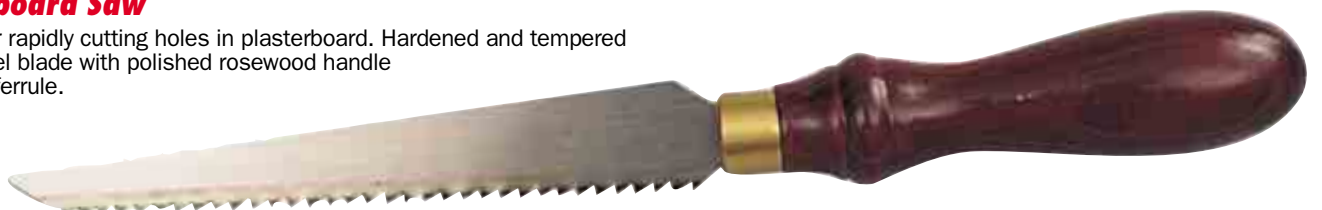

Blade Length	Weight each	Order Code
150mm (6")	105g	KEN-597
-5660K		

GROUP 597 WOODWORKING TOOLS

KENNEDY Flexi Flush Cutting Saw
QUALITY INDUSTRIAL TOOLING

Suitable for precise cutting in confined areas or around obstructions. Flexible alloy steel blade, which cuts on the pull stroke. Polished rosewood handle with brass ferrule. 20tpi.



Blade Length	Weight each	Order Code
155mm (6")	120g	-5520K

Mini Gent's Saws

Suitable for light duty precise cutting. Narrow blade width allows use in confined areas. Polished rosewood handle with brass ferrule. Blade width: 40mm (1½").



Blade Length	Weight each	Order Code
150mm (6")	160g	-5560K

Steel Back Gent's Saws

Suitable for precise flush cutting. Sprung alloy steel blade with rigid steel back, polished rosewood handle and brass ferrule. Blade width: 60mm (2¼").



Blade Length	Weight each	Order Code
150mm (6")	180g	-5460K
200mm (8")	200g	-5480K

Reversible Gent's Saw

Suitable for flush cutting in the most awkward corners on the left or right hand side. Reversible offset alloy steel blade cranked and polished with rigid back. Rosewood handle with brass ferrule. 15tpi.



Blade Length	Weight each	Order Code
250mm (10")	305g	-5400K

Corner Clamp

Ideal for use with wood, angle and tubing. Clamping jaws swivel to accept various widths. Die cast aluminium body with bench mounting.

Overall base dimensions: 158mm x 158mm.
Jaw depth: 36mm.
Slot width: 10mm.

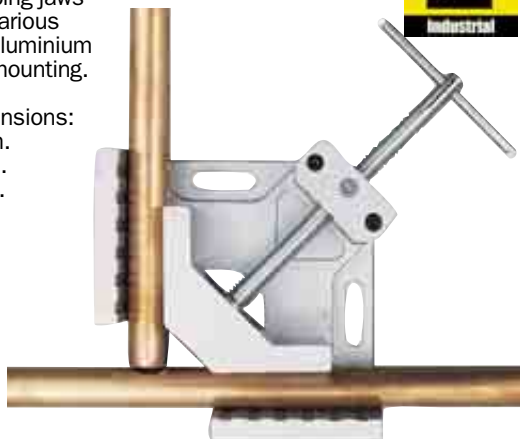

Maximum Clamping	Weight each	Order Code
70 x 70mm	1.40kg	-6000K

Beechwood Sawing Blocks

Mitre box and block pre-cut at 45° and 90°. Bench hook is universal - left and right handed.



Mitre Box

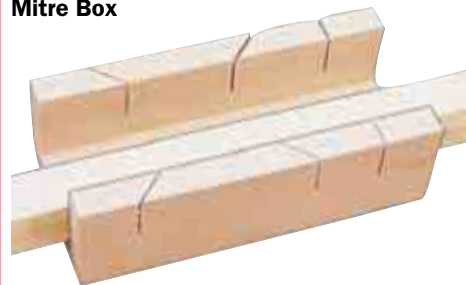

Size Internal (mm)	Order Code
230 x 76	-6090K

Mitre Block

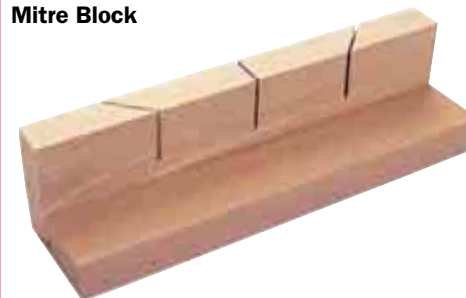

Size Internal (mm)	Order Code
230 x 76	-6190K

Bench Hook

Manufactured from the finest quality beech wood. Hooks into the edge of the bench allowing the workpiece to be held firmly against one end whilst cutting or marking out.



Size Internal (mm)	Order Code
230 x 150	-6290K

Hand Tools

SENATOR Sidewinder Drill
QUALITY TOOLING

Titanium Nitride (TiN) coated for increased tool life and performance. Standard 118° drill point. 6mm shank diameter suitable for use in electric and air powered drills. The side cutting teeth allow the drill to be used for producing any size or shape of hole in wood or plastic.



Diameter (mm)	Overall Length	Weight each	Order Code
6	90mm	150g	-7500K
8	97mm	150g	-7550K

KENNEDY Flat Bits
QUALITY INDUSTRIAL TOOLING

Forged from high quality tool steel with chip clearance groove and hollow ground point. Centerless ground and true running. Ground spade bit head. For cutting holes in laminates and wood. 6mm hexagon shank to prevent slipping at speed.



Cutting mm	Overall Length	Weight each	Order Code KEN-597
9	160	50g	-4070K
13	160	50g	-4110K
16	165	55g	-4150K
19	170	55g	-4190K
22	170	60g	-4230K
25	170	60g	-4280K
32	170	60g	-4290K

Flat Bit Set

Supplied in wallet.

Contents:

9 (3/8"), 13 (1/2"), 16 (5/8"), 19 (3/4"), 22 (7/8") and 25mm (1").



6
PIECES

Number of pieces	Weight each	Order Code KEN-597
6	280g	-4300K

Adjustable Flat Bits

For cutting holes in wood, plastics etc. Cutting diameter can be infinitely varied within range. Graduated scale with locking screw. For use in three jaw chucks. 9.6mm hexagon shank. 170mm overall length.



Cutting Range	Weight per 12	Order Code KEN-597
15-45mm	1.8g	-4400K
22-76mm	2.8g	-4450K

Auger Bits

American pattern with solid single twist. Spur point and hexagon shank for use with hand and power tools. The overall bit length is 230mm.



Dia. Cut	Dia. Shank	Weight each	Order Code KEN-597
6	6	60g	-3030K
9	7	40g	-3070K
13	7	130g	-3110K
16	7	110g	-3150K
19	8	240g	-3190K
22	9	300g	-3230K
25	9	260g	-3280K

Boxed Set

Contents: 1x each 6 (1/4"), 9 (3/8"), 13 (1/2"), 16 (5/8"), 19 (3/4"), 22 (7/8") and 25mm (1").

7
PIECES



Number of pieces	Weight each	Order Code KEN-597
7	860g	-3300K

Adjustable Hole Cutter

For use on metal, wood, plastics, laminates and leather etc. Cutting diameter can be infinitely varied within range. Graduated scale with locking screw. For use in 3 jaw chucks (6.4mm shank).



Maximum cutting thickness: metal 2mm, wood 8mm. Overall length: 95mm. Cutting range: 20 - 76mm.

Weight per 6	Order Code KEN-597
950g	-4520K

Trammel Heads

Supplied as a pair. To be used in conjunction with any wood offcut between 3/4" to 1 1/2" wide, minimum thickness of 3/8". Suitable for scribing arcs and circles.



Overall Length	Weight each	Order Code KEN-597
150mm	490g	-6500K

SENATOR Forstner Bits
QUALITY TOOLING

For precision hole boring. Self piloting point combined with trepanning style cutting action will produce overlapping holes in any direction. Ideal for scroll and scalloping applications. Suitable for use in bench and pillar drills to bore a wide range of timber, plastics and other materials. The overall bit length is 90mm.



Diameter (mm)	Weight each	Order Code SEN-597
10	45g	-5100K
12	45g	-5120K
15	60g	-5150K
16	65g	-5160K
18	65g	-5180K
20	70g	-5200K
22	70g	-5220K
25	90g	-5250K

Diameter (mm)	Weight each	Order Code SEN-597
26	90g	-5260K
28	95g	-5280K
30	105g	-5300K
35	120g	-5350K
40	165g	-5400K
45	180g	-5450K
50	200g	-5500K



Boxed Sets

Contents:
5 Piece: 1x each 15, 20, 25, 30 and 35mm.

15 Piece: 1x each 10, 12, 15, 16, 18, 20, 25, 26, 28, 30, 35, 40, 45 and 50mm.

Number of pieces	Weight each	Order Code SEN-597
5	0.70g	-5650K
15	2.30g	-5670K

5
PIECES

GROUP 601 HEXAGON KEYS

KENNEDY Hexagon Key
QUALITY INDUSTRIAL TOOLING L-Wrenches

Manufactured from fully hardened carbon steel in accordance with **DIN 911** ensuring a quality ductile key with precision square cut ends and accurate AF dimensions to ensure full socket contact. Black finish.



Metric Standard Length

METRIC



Size	Dimensions(mm)		Weight per 100	Order Code
	a	b		KEN-601
1.5	46.0	15.0	0.95kg	-1150K
2.0	52.0	18.0	1.93kg	-1200K
2.5	58.0	20.0	3.36kg	-1250K
3.0	66.0	23.0	5.52kg	-1300K
4.0	74.0	29.0	11.4kg	-1400K
6.0	96.0	38.0	33.3kg	-1600K
7.0	102.0	41.0	48.5kg	-1700K
8.0	108.0	44.0	67.4kg	-1800K
10.0	122.0	50.0	119kg	-2100K
12.0	137.0	57.0	194kg	-2120K
14.0	154.0	70.0	305kg	-2140K
17.0	177.0	80.0	517kg	-2170K
19.0	199.0	89.0	723kg	-2190K
22.0	222.0	102.0	1092kg	-2220K

INCH



Inch Standard Length

Size	Dimensions(mm)		Weight per 100	Order Code
	a	b		KEN-601
0.028"	33	7	0.07kg	-0010K
0.035"	33	11	0.08kg	-0020K
0.050"	41	13	0.11kg	-0030K
1/16"	47	16	0.16kg	-0040K
5/64"	52	18	0.21kg	-0050K
3/32"	58	20	0.32kg	-0060K
7/64"	66	23	0.42kg	-0070K
1/8"	66	23	0.58kg	-0080K
9/64"	72	26	0.77kg	-0090K
5/32"	74	29	1.00kg	-0100K
3/16"	85	33	1.50kg	-0120K
7/32"	91	36	2.16kg	-0140K
1/4"	96	38	3.20kg	-0160K
5/16"	108	44	4.30kg	-0200K
3/8"	122	50	9.20kg	-0240K
7/16"	130	53	13.50kg	-0280K
1/2"	145	63	19.40kg	-0320K
9/16"	154	69	27.00kg	-0360K
5/8"	176	76	36.00kg	-0400K
3/4"	199	89	62.00kg	-0480K
7/8"	222	102	92.00kg	-0560K
1"	275	125	128.00kg	-0640K

Hexagon Key Walleted Sets

Metric 9 Piece Standard Set Contents:

1.5 x 45, 2 x 50, 2.5 x 56, 3 x 63, 4 x 70, 5 x 79, 6 x 90, 8 x 100 and 10 x 112mm.

9
PIECES

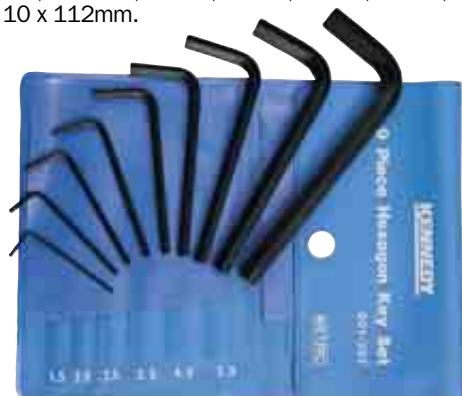

METRIC



Number of Pieces	Weight each	Order Code
9	300g	-2970K

Inch 10 Piece Standard Set Contents:

1/16" x 1 3/4", 5/64" x 1 7/8", 3/32" x 2", 1/8" x 2 1/4", 5/32" x 2 1/2", 3/16" x 2 3/4", 7/32" x 3", 1/4" x 3 1/4", 5/16" x 3 3/4", and 3/8" x 4 1/4".

10
PIECES



INCH



Number of Pieces	Weight each	Order Code
10	290g	-0970K

Key Ring Sets

Metric 8 Piece Set Contents:

1.5, 2, 2.5, 3, 4, 5, 5.5 and 6mm.

8
PIECES



METRIC



Number of Pieces	Weight each	Order Code
8	120g	-2980K

Inch 8 Piece Set Contents:

1/16", 5/64", 3/32", 1/8", 5/32", 3/16", 7/32" and 1/4".

8
PIECES



INCH



Number of Pieces	Weight each	Order Code
8	110g	-0980K

Hand Tools



KENNEDY *Hexagon Key*
QUALITY INDUSTRIAL TOOLING **L-Wrenches - Long Arm**

Manufactured from fully hardened carbon steel in accordance with **DIN 911** ensuring a quality ductile key with precision square cut ends and accurate AF dimensions to ensure full socket contact. Black finish.



Metric Long Arm

Size	Dimensions (mm)		Weight per 100	Order Code KEN-601
	a	b		
1.5	63	15	1.21kg	-4150K
2.0	77	18	2.61kg	-4200K
2.5	87	20	4.59kg	-4250K
3.0	93	23	7.17kg	-4300K
4.0	104	29	14.6kg	-4400K
5.0	120	33	26.3kg	-4500K
6.0	141	38	44.3kg	-4600K
8.0	158	44	89.1kg	-4800K
10.0	180	50	158kg	-5100K
12.0	202	57	257kg	-5120K
14.0	229	70	405kg	-5140K
17.0	262	80	684kg	-5170K
19.0	280	89	922kg	-5190K

METRIC



INCH



Inch Long Arm

Size	Dimensions (mm)		Weight per 100	Order Code KEN-601
	a	b		
1/16"	77	14	0.21kg	-3040K
5/64"	82	15	0.31kg	-3050K
3/32"	88	17	0.44kg	-3060K
7/64"	92	18	0.62kg	-3070K
1/8"	96	19	0.79kg	-3080K
9/64"	101	20	0.81kg	-3090K
5/32"	105	21	1.60kg	-3100K
3/16"	114	24	2.20kg	-3120K
7/32"	124	26	3.40kg	-3140K
1/4"	135	28	4.40kg	-3160K
5/16"	151	32	8.00kg	-3200K
3/8"	170	35	13.00kg	-3240K
1/2"	208	41	28.00kg	-3320K
9/16"	228	44	33.00kg	-3360K
5/8"	250	48	67.00kg	-3400K

Metric 9 Piece Long Arm Set Contents:

1.5 x 77, 2 x 83, 2.5 x 90, 3 x 98, 4 x 106, 5 x 118, 6 x 137, 8 x 156, and 10 x 170mm.

METRIC



Number of Pieces	Weight each	Order Code KEN-601
9	450g	-5970K

Inch 10 Piece Long Arm Set Contents:

1/16" x 3", 5/64" x 3 3/16", 3/32" x 3 1/2", 1/8" x 3 3/4", 5/32" x 4 1/8", 3/16" x 4 1/2", 7/32" x 4 7/8", 1/4" x 5 5/16", 5/16" x 6", and 3/8" x 6 3/4".

INCH



Number of Pieces	Weight each	Order Code KEN-601
10	380g	-3970K

Hexagon T-Handle Wrenches

Manufactured from fully hardened carbon steel. Ergonomically designed handle to provide high grip and torque with user comfort.



METRIC



Metric

Size	Overall Length (mm)	Weight each	Order Code KEN-601
2.0	150	25g	-6030K
2.5	150	30g	-6050K
3.0	150	35g	-6060K
4.0	190	55g	-6080K
5.0	190	70g	-6100K
6.0	225	120g	-6120K
8.0	225	155g	-6160K
10.0	225	220g	-6200K

INCH



Inch

Size	Overall Length (Inch)	Weight each	Order Code KEN-601
3/32"	6"	25g	-6560K
1/8"	6"	30g	-6580K
5/32"	7 1/2"	55g	-6600K
3/16"	7 1/2"	65g	-6620K
1/4"	9"	130g	-6660K
5/16"	9"	160g	-6700K
3/8"	9"	210g	-6740K

Metric 5 Piece Set Contents:

4, 5, 6, 8 and 10mm.

Metric 8 Piece Set Contents:

2, 2.5, 3, 4, 5, 6, 8 and 10mm.



METRIC



Number of Pieces	Weight each	Order Code KEN-601
5	685g	-6450K
8	765g	-6470K

CV Hex Keys

Manufactured from chrome vanadium steel with a nickel plating. Manufactured to **ISO2936** (formerly **DIN 911L**). Set supplied in an indexed plastic holder. Individual hexagon key slots help to instantly identify missing keys.

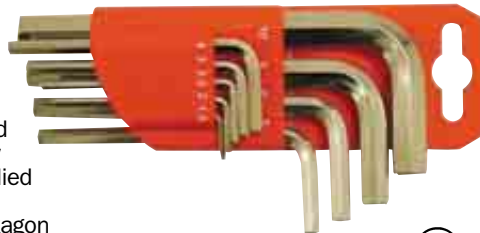

METRIC



Size (mm)	Overall Length (mm)	Order Code KEN-601
1.5	45	-7520K
2.0	50	-7540K
2.5	55	-7560K
3.0	60	-7580K
4.0	75	-7600K
5.0	85	-7620K
6.0	95	-7640K
8.0	110	-7660K
10.0	120	-7680K
9 piece Set	1 of each above	-7990K

KENNEDY Pro-Torg Hex PROFESSIONAL Wrench Sets on Clip

Supplied on robust plastic clips. Keeps all sizes together and readily available. Conveniently folds up to a handy pocket size with penknife type storage. Wrench size stamped on clip.



Size	Weight each	Order Code KEN-601
5/64" - 1/4"	160g	-1020K
1.5 - 8mm	160g	-3020K

GROUP 602 HEXAGON BALL DRIVERS

KENNEDY Pro-Torq T-Handled Hexagon PROFESSIONAL Ball Drivers

Manufactured from hardened carbon steel with a dual material 'T' handle grip for comfort and extra force. The ball drivers can be used at angles of up to 30° for use where access is restricted and the shorter hexagon end is ideal for use when a greater tightening torque is required. Long arm end is ball drive and short arm end plain. Black oxidised finish. Manufactured to **ISO2936/DIN911**.



NEW

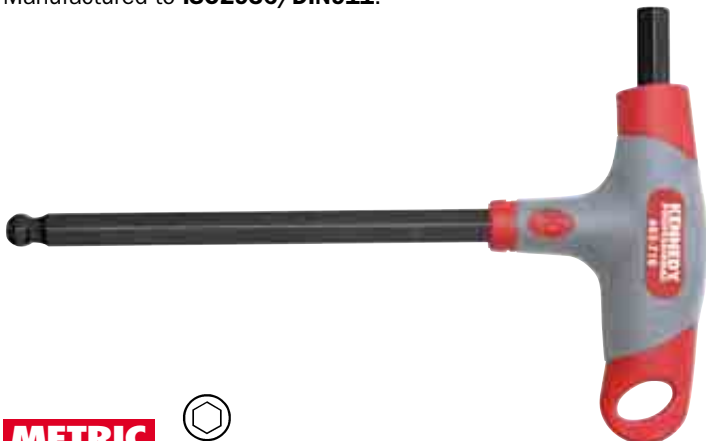

METRIC



Size	Overall Length	Weight each	Order Code KEN-602
2.0	130mm		-7010K
2.5	140mm		-7020K
3.0	150mm		-7030K
4.0	160mm		-7040K
5.0	175mm		-7050K
6.0	185mm		-7060K
8.0	195mm		-7080K
10.0	205mm		-7100K

8 Piece Set Contents:
2, 2.5, 3, 4, 5, 6, 8 and 10mm.

METRIC



Description	No. of Pieces	Weight each	Order Code KEN-602
Pro-Torq Ball Driver Set	8	750g	-7800K

KENNEDY Ball Driver QUALITY INDUSTRIAL TOOLING L-Wrenches

Manufactured from fully hardened carbon steel in accordance with **DIN 911**. A quality ductile key with precision cut ends and accurate AF dimensional to ensure maximum socket contact. Ball end allows up to 30° work offset. Long arm end is ball drive and short arm end plain. Black oxidised finish.



Metric

METRIC



Size (mm)	Overall Length	Weight per 100	Order Code KEN-602
1.5	63mm	1.21kg	-3030K
2.0	77mm	2.61kg	-3040K
2.5	87mm	4.59kg	-3050K
3.0	93mm	7.17kg	-3060K
4.0	104mm	14.6kg	-3080K
5.0	120mm	26.2kg	-3100K
6.0	141mm	44.3kg	-3120K
7.0	147mm	63.5kg	-3140K
8.0	158mm	89.1kg	-3160K
10.0	180mm	158kg	-3200K

Inch

INCH



Size	Overall Length	Weight per 100	Order Code KEN-602
0.050"	77mm	0.30kg	-4030K
1/16"	77mm	0.32kg	-4040K
5/64"	82mm	0.32kg	-4050K
3/32"	89mm	0.46kg	-4060K
7/64"	96mm	0.64kg	-4070K
1/8"	101mm	0.86kg	-4080K
9/64"	105mm	1.10kg	-4090K
5/32"	113mm	2.10kg	-4100K
3/16"	124mm	2.30kg	-4120K
7/32"	134mm	3.40kg	-4140K
1/4"	150mm	2.80kg	-4160K
5/16"	162mm	8.00kg	-4200K
3/8"	186mm	26.00kg	-4240K

Metric 7 Piece Set Contents: 1.5, 2, 2.5, 3, 4, 5 and 6mm.

Metric 9 Piece Set Contents: 1.5, 2, 2.5, 3, 4, 5, 6, 8 and 10mm.

Inch 7 Piece Set Contents: 5/64", 3/32", 7/64", 1/8", 9/64", 5/32" and 3/16".

Inch 9 Piece Set Contents: 5/64", 3/32", 1/8", 5/32", 3/16", 7/32", 1/4", 5/16" and 3/8".



Supplied in a plastic storage clip.

METRIC



Number of Pieces	Weight each	Order Code KEN-602
7	110g	-4570K
9	350g	-5500K



Supplied in a plastic storage clip.

INCH



Number of Pieces	Weight each	Order Code KEN-602
7	80g	-5580K
9	370g	-5730K

Hand Tools



HEXAGON BALL DRIVERS

KENNEDY Hexagon T-Handle Ball Drivers
QUALITY INDUSTRIAL TOOLING

Manufactured from fully hardened carbon steel. Ergonomically designed handle to provide high grip and torque with user comfort.

METRIC



Metric

Size (mm)	Overall Length	Weight each	Order Code KEN-602
2.5	150mm	25g	-6050K
3.0	150mm	30g	-6060K
4.0	150mm	60g	-6080K
5.0	190mm	70g	-6100K
6.0	190mm	120g	-6120K
8.0	230mm	170g	-6160K
10.0	230mm	230g	-6200K

Metric 5 Piece Set Contents:

4, 5, 6, 8 and 10mm.

Metric 7 Piece Set Contents:

2.5, 3, 4, 5, 6, 8 and 10mm.



METRIC



Number of Pieces	Weight each	Order Code KEN-602
5	650g	-7650K
7	1007g	-7770K

Hexagon Ball Driver Hand Clip Sets

Metric 7 Piece Set Contents:

2.5, 3, 4.5, 6, 8 and 10mm.



METRIC



Number of Pieces	Weight each	Order Code KEN-602
7	360g	-8070K

KENNEDY Pro-Torq Hexagon PROFESSIONAL Ball Wrench Clip Set

Conveniently folds up to a handy pocket size with penknife type storage. Moulded handle that gives excellent grip and user comfort.

Sizes: 1.5 - 8mm.

Dimensions:
40mm (w)
22mm (d)
115mm (h)



METRIC



Number of Pieces	Weight each	Order Code KEN-602
8	169g	-8280K

INCH



Inch

Size	Overall Length	Weight each	Order Code KEN-602
3/32"	6"	30g	-6560K
1/8"	6"	40g	-6580K
5/32"	7 1/2"	60g	-6600K
3/16"	7 1/2"	70g	-6620K
7/32"	9"	90g	-6640K
1/4"	9"	140g	-6660K
5/16"	9"	165g	-6700K
3/8"	9"	210g	-6740K

CV Ball Drivers

Manufactured from chrome vanadium steel with a nickel plating. Manufactured to **ISO2936 (formerly DIN 911L)**.

Set supplied in an indexed plastic holder. Individual hexagon key slots help to instantly identify missing drivers.



METRIC



Metric

Size (mm)	Overall Length	Order Code KEN-602
1.5	80mm	-9030K
2.0	85mm	-9040K
2.5	90mm	-9050K
3.0	100mm	-9060K
4.0	110mm	-9080K
5.0	130mm	-9100K
6.0	150mm	-9120K
8.0	175mm	-9160K
10.0	200mm	-9200K
9 Piece Set 1 of each above		-9940K

Inch 7 Piece Set Contents:

3/32", 1/8", 5/32", 3/16", 1/4", 5/16" and 3/8".

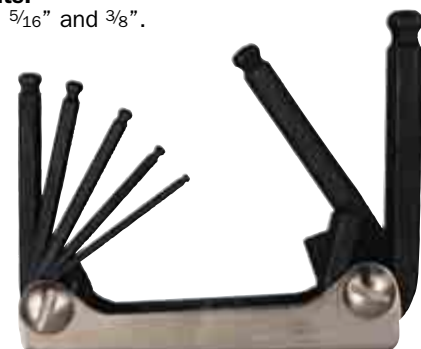

INCH



Number of Pieces	Weight each	Order Code KEN-602
7	465g	-8170K

Pro-Torq Hexagon Ball Wrench Clip Set

Conveniently folds up to a handy pocket size with penknife type storage. Moulded handle that gives excellent grip and user comfort.

Sizes: 5/64" - 1/4".

Dimensions:
40mm (w)
22mm (d)
115mm (h)



INCH



Number of Pieces	Weight each	Order Code KEN-602
9	149g	-8390K

GROUP 602 HEXAGON BALL DRIVERS

KENNEDY Hexagon
QUALITY INDUSTRIAL TOOLING **Ball Drivers**

Can be used at angles of up to 30° from the screw head, making them ideal for awkward access areas. Manufactured from hardened carbon steel, available with fluted driver handles, L-wrench pattern or T-handle.



METRIC 			
Metric Size (mm)	Blade Length	Weight Per 10	Order Code KEN-602
1.5	86mm	65g	-1030K
2.0	89mm	90g	-1040K
2.5	99mm	120g	-1050K
3.0	81mm	200g	-1060K
4.0	97mm	450g	-1080K
5.0	109mm	710g	-1100K
6.0	137mm	910g	-1120K
8.0	163mm	1580g	-1160K
10.0	185mm	1840g	-1200K

INCH 			
Inch Size (mm)	Blade Length	Weight Per 10	Order Code KEN-602
1/16"	84mm	90g	-2040K
5/64"	89mm	110g	-2050K
1/8"	79mm	200g	-2080K
9/64"	84mm	400g	-2090K
5/32"	89mm	550g	-2100K
3/16"	96mm	1380g	-2120K
1/4"	119mm	1320g	-2160K
3/8"	165mm	1530g	-2240K

Hexagon Ball Driver Sets

Metric 6 Piece Set Contents:
1.5, 2, 2.5, 3, 4 and 5mm.

Metric 9 Piece Set Contents:
1.5, 2, 2.5, 3, 4, 5, 6, 8, and 10mm.

Inch 8 Piece Set Contents:
1/16", 5/64", 1/8", 9/64", 5/32", 3/16", 1/4" and 3/8".



METRIC 		
Number of Pieces	Weight each	Order Code KEN-602
6	170g	-2560K

METRIC 		
Number of Pieces	Weight each	Order Code KEN-602
9	640g	-2590K

INCH 		
Number of Pieces	Weight each	Order Code KEN-602
8	480g	-2640K

Hand Tools

KENNEDY L-Wrench TX Keys
QUALITY INDUSTRIAL TOOLING

Manufactured from chrome molybdenum steel.



Size	Length (mm)	Weight each	Order Code
T6	46	20g	-0060K
T7	52	20g	-0070K
T8	52	30g	-0080K
T9	54	30g	-0090K
T10	54	40g	-0100K
T15	58	55g	-0150K
T20	61	75g	-0200K

Size	Length (mm)	Weight each	Order Code
T25	63	100g	-0250K
T27	69	160g	-0270K
T30	78	210g	-0300K
T40	85	310g	-0400K
T45	92	445g	-0450K
T50	100	640g	-0500K
T55	120	1200g	-0550K

TX KEYS

9 Piece Set

Contents: T8, T9, T10, T15, T20, T25, T27, T30 and T40. Supplied in a plastic storage clip.



No. of Pieces	Weight each	Order Code
9	155g	-0760K

L-Wrench TXS (Tamper Proof) Keys

TXS Tamper-proof TX keys are the same shape as standard TX keys, but have a security hole in the middle. Manufactured from chrome molybdenum steel.



Size	Length (mm)	Weight each	Order Code
T8	52	30g	-2080K
T9	54	30g	-2090K
T10	54	40g	-2100K
T15	58	55g	-2150K
T20	61	75g	-2200K

Size	Length (mm)	Weight each	Order Code
T25	63	100g	-2250K
T27	69	160g	-2270K
T30	78	210g	-2300K
T40	85	310g	-2400K

9 Piece Set Contents:

T8, T9, T10, T15, T20, T25, T27, T30 and T40. Supplied in a plastic storage clip.



No. of Pieces	Weight each	Order Code
9	102g	-2680K

KENNEDY TX Key Ring Set
QUALITY INDUSTRIAL TOOLING

8 Piece Set Contents: T9, T10, T15, T20, T25, T27, T30 and T40.



No. of Pieces	Weight each	Order Code
8	120g	-0720K

KENNEDY Pro-Torq TX PROFESSIONAL Wrench Set on Clip

8 keys supplied on robust plastic clip. Keeps all sizes together and readily available. Conveniently folds up to a handy pocket size with penknife type storage. Wrench size stamped on clip.



Size	Weight each	Order Code
T9 - T40	164g	-1680K

KENNEDY Driver Style TX Keys
QUALITY INDUSTRIAL TOOLING

Screwdriver handle style wrenches. Suitable for all applications but particularly favoured for use when replacing shims and inserts on replaceable tipped carbide tooling. Also favoured by the electronics industry. Made from chrome molybdenum steel. Each driver is marked with size.



Size	Length (mm)	Weight each	Order Code
T6	61	30g	-0060D
T7	61	32g	-0070D
T9	75	60g	-0090D
T10	75	60g	-0100D
T25	100	100g	-0250D

PRODUCTS ARE ONLY AVAILABLE VIA YOUR DISTRIBUTOR